



## Stock List

### NEW Chester D13R

#### 1005304870N - Drilling Machine - Pillar

Distance Spindle /Table (mm): 220, Quill Stroke (mm): 60, Throat (mm): 125, Main Drive Power (KW/V/Hz): 1/2hp, Table Surface Area (mm): 190 x 195, Speeds: 468 - 2480rpm, Spindle Taper: B16, Diameter (mm): 13

£207



### NEW Chester D19

#### 1005305216N - Drilling Machine - Pillar

Table Area: 290mm x 290mm, Main Drive Power KW/V/Hz: 240 volt., Max Drilling Capacity: 20mm, Spindle Taper: MT2, Spindle Speeds: 120 - 2580 rpm, Column Diameter: 80mm, Max Distance spindle nose to base: 600mm, Distance Spindle /Table (mm): 410mm, Throat (mm): 178mm, Main Drive Power (KW/V/Hz): 240volt

£550



## NEW Chester D13

### 1005305807N - Drilling Machine - Bench

Distance Spindle /Table (mm): 210mm, Quill Stroke (mm): 50mm, Throat (mm): 104mm, Main Drive Power (KW/V/Hz): 240v/1ph/50hz, Table Surface Area (mm): 165x160mm, Speeds: 600 - 2500rpm, Spindle Taper: B16, Max Distance spindle nose to base: 350mm, Column Diameter: 48, Maximum Drilling Capacity: 13mm, Chuck size: 1 - 13mm, Overall height: 585mm, Base size: 280 x 175mm, Motor: 250w, Weight: 17kgs

£127



## NEW Chester D16

### 1005604330N - Drilling Machine - Bench

Diameter (mm): 16, Speeds: 180-2740, Table Surface Area (mm): 300 Dia, Spindle Taper: MT2, Main Drive Power (KW/V/Hz): 3/4hp, Throat (mm): 165, Quill Stroke (mm): 70mm, Distance Spindle /Table (mm): 520

£450



# NEW Chester PRO 18VS

## 1010305215N - Drilling Machine - Pillar

Spindle Taper: MT3, Diameter of Quill: 70mm, Chuck Capacity: 16mm, Quill Travel: 120mm, Distance spindle to Table: 745mm, Distance spindle to Column: 225mm, Size of table: 405 x 320mm, Size of base: 550 x 370mm, Column Diameter: 95mm, Motor: 240v/2hp, Range of speeds: 85-1900rpm, Dimensions: 900 x 500 x 1800mm, Weight: 350 Kgs

£1,415



# NEW Kitchen & Walker GV25 S

## 1010604624N - Drilling Machine - Vari Speed Pillar with Tapping

Max Drilling Capacity: 25mm, Spindle Taper: 3 morse, Spindle Speeds: 150-3000 rpm, Main Drive Power KW/V/Hz: 1.5kw, Table Area: 460 x 360mm, Max Drilling Stroke: 135, Column Diameter: 92mm, Max Tapping Capacity: 16mm, Quill Stroke: 135mm, Throat: 204mm, Max Distance spindle nose to table: 625mm, Max Distance spindle nose to base: 1115mm, Dimensions: 740x450x1700mm, Net weight: 220 kilos

£2,520



## NEW Chester D32

### 1010604838N - Drilling Machine - Pillar

Capacity: 32mm , Speed Range: 150-2700 rpm, 12 speeds, Taper: No 4 MT, Throat: 254mm, Spindle Travel: 115mm, Table Size: 420mm x 470mm, Column Dia: 90mm

£960



## NEW Chester Pro 25

### 1010605604N - Drilling Machine

Max Drilling Capacity: 32mm, Spindle Taper: 3 morse, Spindle Speeds: 160-1880rpm, Main Drive Power: 240v or 415v (please specify), Table Area: 340 x 380mm, Max Drilling Stroke: 130mm, Throat: 230mm, Column Diameter: 102mm, Number of T Slots: 2, Overall Dimensions: 1680 x 435 x 840mm, Weight: 190 kgs

£1,311



## NEW Chester Pro 20

### 1010606907N - Drilling Machine

Max Drilling Capacity: 25mm, Spindle Taper: 2 morse, Spindle Speeds: 160-1820rpm, Main Drive Power: 240v or 415v (please specify), Table Area: 245 x 245mm, Max Drilling Stroke: 93mm, Throat: 230mm, Column Diameter: 85mm, Number of T Slots: 2, Overall Dimensions: 1050 x 360 x 680mm, Weight: 108 kgs

£966



## NEW Chester FD25G

### 1010607043N - Drilling Machine - All Geared Head Pillar

Control: Hand Operated, Max Drilling Capacity: 35mm Iron / 25mm Steel, Spindle Taper: MT3, Spindle Speeds: 100-2900, Main Drive Power KW/V/Hz: 1hp, Table Area: 310 x 275, Max Drilling Stroke: 140, Feeds: optional, Column Diameter: 100

£1,998



## NEW Chester D20

### 1010607269N - Drilling Machine - Pillar

Capacity: 20mm (not ms), Speed Range: 120-2580rpm, Taper: MT2, Throat: 178mm, Spindle Travel: 80mm, Table Size: 285 x 285mm, Column Dia: 70mm

£500



## NEW Chester BD25G

### 1010607297N - Drilling Machine - All Geared Head Pillar

Control: Hand Operated, Max Drilling Capacity: 35mm Iron / 25mm Steel, Spindle Taper: MT3, Spindle Speeds: 100-2900, Main Drive Power KW/V/Hz: 1hp, Table Area: 310 x 275, Max Drilling Stroke: 140, Feeds: optional, Column Diameter: 100, Bench: Yes

£1,230



## NEW Kitchen & Walker GP50 plus

### 1010904422N - Drilling Machine - Pillar, All Geared Head Heavy Duty

Max Drilling Capacity: 80mm Iron / 50mm Steel, Spindle Taper: MT5, Spindle Speeds: 31-1400rpm, Main Drive Power KW/V/Hz: 4hp, Table Area: 480 x 560, Max Drilling Stroke: 250, Feeds: 8

£6,700



## NEW Kitchen & Walker GV32 S

### 1010904625N - Drilling Machine - Variable Speed Pillar with Tapping

Max Drilling Capacity - Steel: 32mm, Spindle Taper: 4 morse, Spindle Speeds: 150-2500 rpm Variable speed, Main Drive Power KW/V/Hz: 1.5 / 2.2kw, Table Area: 400 x 500, Max Drilling Stroke: 150mm, Tapping capacity - Steel: 16mm, Throat : 240mm, Column Diameter: 92mm, Spindle nose to table: 735mm, Spindle nose to base: 1150mm, Net Weight : 265kg

£4,100



## NEW Kitchen & Walker GP35A

### 1010904821N - Drilling Machine - Pillar, All Geared Head

Max Drilling Capacity: 50mm CI / 35mm Steel, Spindle Taper: 4, Spindle Speeds: 100-1450, Main Drive Power KW/V/Hz: 2 HP, Table Area: 560 x 560, Max Drilling Stroke: 180, Feeds: 2

£6,480



## NEW Chester PRO 17 VS

### 1010905214N - Drilling Machine - Pillar

Spindle Taper: MT3, Max Chuck Capacity: 16mm, Size Of Table: 345 x 345mm, Motor: 240v/1100w or 415vlt, Spindle Speeds: 280-2500rpm, Column Diameter: 80mm, Diameter of Quill: 50mm, Quill Travel: 80mm, Max Distance Spindle to Table: 780mm, Spindle to Column: 222mm, Size of Base: 520 x 320mm, Dimensions: 800 x 450 x 1700mm, Weight: 100 Kgs

£587



## NEW Kitchen & Walker GP25

### 1010905500N - Drilling Machine - Pillar, All Geared Head

Max Drilling Capacity: 25mm Steel, Spindle Taper: 3, Spindle Speeds: 125-2825, Main Drive Power KW/V/Hz: 0.75, Table Area: 400 x 330, Max Drilling Stroke: 110

£3,000

# NEW Kitchen & Walker GP35

## 1010907036N - Drilling Machine

Table Area: 440x330mm, Main Drive Power KW/V/Hz: 415 volts, Feeds: 3, Max Drilling Stroke: 190mm, Spindle Speeds: 75-2020rpm, Spindle Taper: MT4, Column Diameter: 140mm, Max Drilling Capacity: 35mm, Accessories: Drill chuck / Lamp / Coolant System, Weight: 600kgs, Spindle to Column: 340mm, Max Distance Spindle to Table: 580mm, Dimensions: 885x640x2275mm

£6,500



# NEW Chester PR60E

## 1010907042N - Drilling Machine

Table Working Area: 560 x 560, Main Drive Power KW/V/Hz: 1.5kw, Feeds: 4 @ 0.1-0.2mm/r, Max Drilling Stroke: 180, Spindle Speeds: 50-1450rpm, Spindle Taper: MT4, Column Diameter: 150, Weight: 465kg, Working Size of Base: 730 x 500, Max Distance Spindle to Table: 770, Maximum Capacity: Drilling 40mm / Tapping M20, Interlocked Chuck Guard: Yes, Dimensions: 2270 x 690 x 1100

£3,910



## NEW Kitchen & Walker GP40

### 1010907199N - Drilling Machine

Table Area: 440x330mm, Main Drive Power KW/V/Hz: 415 volts, Feeds: 3, Max Drilling Stroke: 190mm, Spindle Speeds: 75-2020rpm, Spindle Taper: MT4, Column Diameter: 140mm, Max Drilling Capacity: 35mm, Accessories: Drill chuck / Lamp / Coolant System, Weight: 600kgs, Spindle to Column: 340mm, Max Distance Spindle to Table: 580mm, Dimensions: 885x640x2275mm

£8,000



## NEW Kitchen & Walker GB25

### 1010907200N - Drilling Machine - All Geared Head

Max Drilling Capacity: 25mm Steel, Spindle Taper: 3, Spindle Speeds: 125-2825, Main Drive Power KW/V/Hz: 0.75, Table Area: 400 x 330, Max Drilling Stroke: 110

£2,530



## NEW Kitchen & Walker GV32 SF

### 1010907500N - Pillar Drill Variable speed with Flow Drilling

Max Drilling Capacity - Steel: 32mm, Spindle Taper: 4 morse, Spindle Speeds: 100-4000 rpm Variable speed, Main Drive Power KW/V/Hz: 1.5 / 2.2kw, Table Area: 560 x 470mm, Max Drilling Stroke: 150mm, Tapping capacity - Steel: 19mm, Throat : 265mm, Column Diameter: 115mm, Spindle nose to table: 860mm, Spindle nose to base: 1185mm, Net Weight : 340kg, Flow Drill Capacity: 12mm

£4,500



## NEW Kitchen & Walker GV40 S

### 1010907501N - Pillar Drill Variable speed with Tapping

Max Drilling Capacity - Steel: 34mm, Spindle Taper: 4 morse, Spindle Speeds: 65-2000 rpm Variable speed, Main Drive Power KW/V/Hz: 1.5 Kw, Table Area: 560 x 470mm, Max Drilling Stroke: 150mm, Tapping capacity - Steel: 24mm, Throat : 265mm, Column Diameter: 115mm, Spindle nose to table: 605mm, Spindle nose to base: 1150mm, Net Weight : 385kg

£4,090



## NEW Kitchen & Walker G32 x 800

### 1020304424N - Radial Drilling Machine

Radius Of Arm: 800mm, Spindle Taper: No4 MT, Elevating Arm / Table / Portable / Unive: Elevating Arm, Spindle Speeds: 72-1243 rpm, Main Drive Power KW/V/Hz: 2 hp, Table Area: 500 x 400 x 380, Max Drilling Capacity: 42mm Iron / 32mm Steel, Throat: 800mm, Max Distance base to spindle: 1000mm, Max Drilling Depth: 210mm, Feeds: 3, Weight: 1075 kgs

£7,800



## NEW Kitchen & Walker G38 x 900

### 1020307191N - Radial Drilling Machine

Max Distance Spindle Axis to column: 900 mm, Spindle Taper: MT4, Elevating Arm / Table / Portable / Unive: Elevating Arm, Spindle Speeds: 75 - 1250 rpm, Main Drive Power KW/V/Hz: 1.5 KW / 2hp, Table Area: 600 x 450 x 350 mm, Max Drilling Capacity: Steel 38mm / Iron 48mm, Max Travel Of Drilling Head On Slide: 650mm, Max Workpiece Height: 1120mm, Max Drilling Depth: 210mm, Feeds: 3, Weight: 1250 kgs

£9,300



## NEW Kitchen & Walker G40 x 1300 VS

### 1020307192N - Radial Drilling Machine

Radius Of Arm: 1300mm, Spindle Taper: MT4, Elevating Arm / Table / Portable / Unive: Elevating Arm, Spindle Speeds: 54-2150 rpm Variable speed, Main Drive Power KW/V/Hz: 2.2 KW / 2.95hp, Table Area: 630 x 500 x 400, Max Drilling Capacity: Steel 40mm / Iron 52mm, Max Travel Of Drilling Head On Slide: 1000mm, Max Workpiece Height: 1300mm, Max Drilling Depth: 260mm, Feeds: 4, Weight: 2300 kgs

£15,000



## NEW Kitchen & Walker G45 x 1100

### 1020307193N - Radial Drilling Machine

Radius Of Arm: 1100mm, Spindle Taper: MT4, Elevating Arm / Table / Portable / Unive:  
Elevating Arm, Spindle Speeds: 72 - 1243 rpm, Main Drive Power KW/V/Hz: 2.25kw / 3hp,  
Table Area: 700 x 500 x 360mm, Max Drilling Capacity: steel 45mm / Iron 55mm, Max  
Travel Of Drilling Head On Slide: 840mm, Max Workpiece Height: 1200mm, Max Drilling  
Depth: 220mm, Feeds: 3, Weight: 1600kgs

£11,300



## NEW Kitchen & Walker G50 x 1600

### 1020604324N - Radial Drilling Machine

Radius Of Arm: 1600mm, Spindle Taper: MT5, Elevating Arm / Table / Portable / Unive:  
Elevating Arm, Spindle Speeds: 25-2000rpm, Main Drive Power KW/V/Hz: 3kw / 4 hp,  
Table Area: 630 x 500 x 500, Max Drilling Capacity: 75mm Iron / 50mm Steel, Control:  
Power Feeds, Throat: 1600, Max Travel Of Drilling Head On Slide: 1250, Max Workpiece  
Height: 1220, Max Drilling Depth: 315, Feeds: 16, Weight: 3500kgs

£18,000



## NEW Kitchen & Walker G63 x 2000

### 1020605744N - Radial Drilling Machine

Radius Of Arm: 2000mm, Spindle Taper: No5, Elevating Arm / Table / Portable / Unive:  
Elevating Arm, Spindle Speeds: 20-1600rpm, Main Drive Power KW/V/Hz: 5.5 hp, Table  
Area: 630 x 500 x 800, Max Drilling Capacity - steel: 63mm, Control: Power Feeds, Throat:  
1600, Max Travel Of Drilling Head On Slide: 1250, Max Workpiece Height: 1600, Max  
Drilling Depth: 400, Feeds: 16, Maximum Drilling Capacity - Iron: 100mm

£39,000

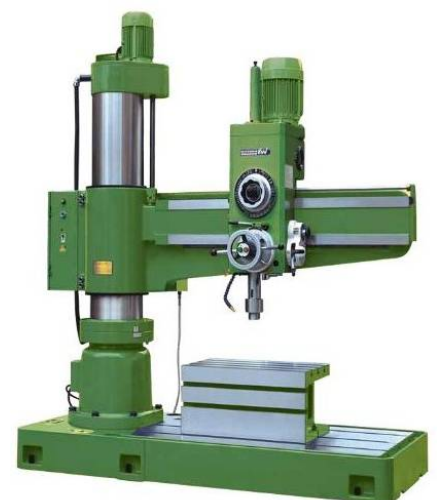

## NEW Kitchen & Walker G100 x 3100

### 1020606206N - Radial Drilling Machine

Radius Of Arm: 3000mm, Spindle Taper: No6, Elevating Arm / Table / Portable / Unive:  
Elevating Arm, Spindle Speeds: 8-1000rpm, Main Drive Power KW/V/Hz: 15 hp, Table  
Area: 800 x 630 x 500, Max Drilling Capacity - steel: 100mm, Control: Power Feeds, Throat:  
1600, Max Workpiece Height: 570, Max Drilling Depth: 315, Feeds: 16, Maximum Drilling  
Capacity - Iron: 150mm

£87,600



## NEW Kitchen & Walker G32 x 1000

### 1020607033N - Radial Drilling Machine

Radius Of Arm: 1000mm, Spindle Taper: MT4, Elevating Arm / Table / Portable / Unive:  
Elevating Arm, Spindle Speeds: 32-2500rpm, Main Drive Power KW/V/Hz: 3 hp, Table  
Area: 400 x 400 x 500, Max Drilling Capacity: 50mm Iron / 32mm Steel, Throat: 1000, Max  
Workpiece Height: 1000, Max Drilling Depth: 280, Feeds: 16, Weight: 1600 kgs

£10,600



## NEW 136Kitchen & Walker G50 x 1400 VS

### 1020607194N - Radial Drilling Machine

Radius Of Arm: 1400mm, Spindle Taper: MT5, Elevating Arm / Table / Portable / Unive:  
Elevating Arm, Spindle Speeds: 38-2000rpm Variable Speed, Main Drive Power KW/V/Hz:  
4 hp, Table Area: 630 x 500 x 500, Max Drilling Capacity: 60mm Iron / 50mm Steel,  
Control: Power Feeds, Throat: 1400mm, Max Travel Of Drilling Head On Slide: 1050mm,  
Max Workpiece Height: 1200, Max Drilling Depth: 280, Feeds: 6, Weight: 3200kgs

£13,600

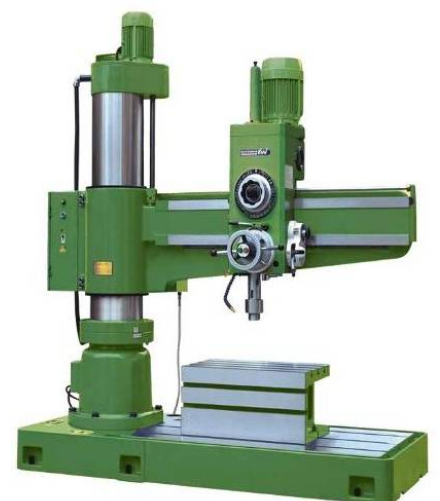

## NEW Kitchen & Walker G62 x 1600VS

### 1020607195N - Radial Drilling Machine

Radius Of Arm: 1600mm, Spindle Taper: MT5, Elevating Arm / Table / Portable / Unive: Elevating Arm, Spindle Speeds: 38-275 / 275-2000rpm Variable Speed, Main Drive Power KW/V/Hz: 4kw / 5.3hp, Table Area: 630 x 500 x 500, Max Drilling Capacity: 72mm Iron / 62mm Steel, Control: Power Feeds, Throat: 1600mm, Max Travel Of Drilling Head On Slide: 1250mm, Max Workpiece Height: 1250mm, Max Drilling Depth: 315mm, Feeds: 8, Weight: 3500kgs

£16,000



## NEW Kitchen & Walker G70 x 1600

### 1020607196N - Radial Drilling Machine

Radius Of Arm: 1600mm, Spindle Taper: No5, Elevating Arm / Table / Portable / Unive: Elevating Arm, Spindle Speeds: 20-1600rpm, Main Drive Power KW/V/Hz: 5.5 hp, Table Area: 630 x 500 x 800, Max Drilling Capacity - steel: 63mm, Control: Power Feeds, Throat: 1600, Max Travel Of Drilling Head On Slide: 1250, Max Workpiece Height: 1600, Max Drilling Depth: 400, Feeds: 16, Maximum Drilling Capacity - Iron: 100mm

£28,200

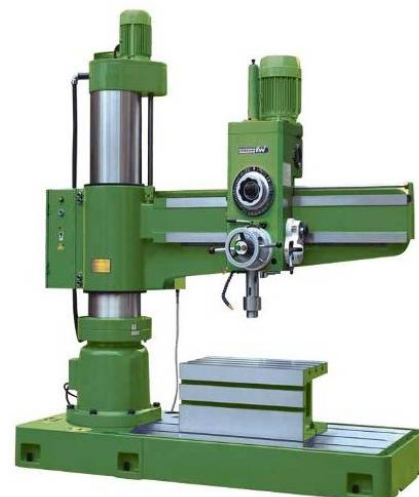

## NEW Kitchen & Walker G80 x 2500 VS

### 1020607197N - Radial Drilling Machine

Radius Of Arm: 2500mm, Spindle Taper: MT6, Elevating Arm / Table / Portable / Unive: Elevating Arm, Spindle Speeds: 30-1400 rpm Variable speed, Main Drive Power KW/V/Hz: 10 hp, Table Area: 630 x 500 x 500, Max Drilling Capacity - steel: 80mm, Control: Power Feeds, Throat: 2500mm, Max Travel Of Drilling Head On Slide: 2000mm, Max Workpiece Height: 2000mm, Max Drilling Depth: 450mm, Feeds: 16, Maximum Drilling Capacity - Iron / Steel: 105mm / 80mm

£37,500

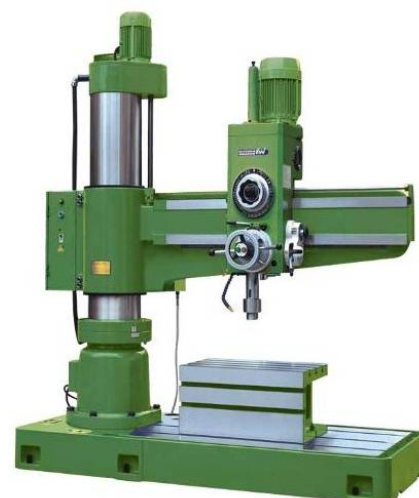

## NEW Kitchen & Walker G125 x 4000

### 1020607198N - Radial Drilling Machine

Radius Of Arm: 3100mm, Spindle Taper: No5, Elevating Arm / Table / Portable / Unive:  
Elevating Arm, Spindle Speeds: 20-1600rpm, Main Drive Power KW/V/Hz: 5.5 hp, Table  
Area: 630 x 500 x 800, Max Drilling Capacity - steel: 63mm, Control: Power Feeds, Throat:  
1600, Max Travel Of Drilling Head On Slide: 1250, Max Workpiece Height: 1600, Max  
Drilling Depth: 400, Feeds: 16, Maximum Drilling Capacity - Iron: 100mm

£171,300

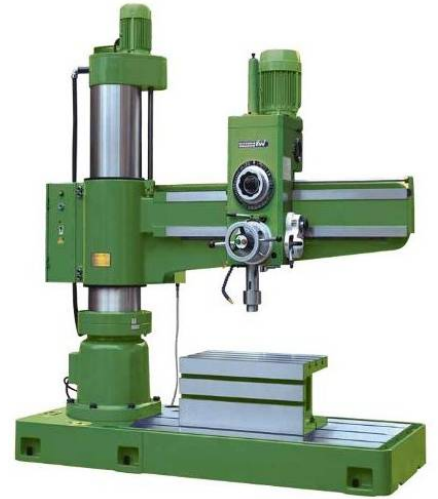

## NEW Kitchen & Walker G55 x 1300

### 1020607240N - Radial Drilling Machine

Radius Of Arm: 1300mm, Spindle Taper: MT5, Elevating Arm / Table / Portable / Unive:  
Elevating Arm, Spindle Speeds: 26-1620 rpm, Main Drive Power KW/V/Hz: 1.5kw / 2hp,  
Table Area: 850 x 500 x 400, Max Drilling Capacity: 66mm Iron / 55mm Steel, Control:  
Power Feeds, Throat: 1300mm, Max Travel Of Drilling Head On Slide: 990mm, Max  
Workpiece Height: 1425mm, Max Drilling Depth: 400mm, Feeds: 8, Weight: 3900kgs

£20,300



## NEW Kitchen & Walker G80 x 2000 VS

### 1020607498N - Radial Drilling Machine

Radius Of Arm: 2050mm, Spindle Taper: MT6, Elevating Arm / Table / Portable / Unive:  
Elevating Arm, Spindle Speeds: 30-1400 rpm Variable speed, Main Drive Power KW/V/Hz:  
10 hp, Table Area: 630 x 500 x 500, Max Drilling Capacity - steel: 80mm, Control: Power  
Feeds, Throat: 2500mm, Max Travel Of Drilling Head On Slide: 450-2050mm, Max  
Workpiece Height: 1620mm, Max Drilling Depth: 400mm, Feeds: 8, Maximum Drilling  
Capacity - Iron / Steel: 105mm / 80mm

£33,400

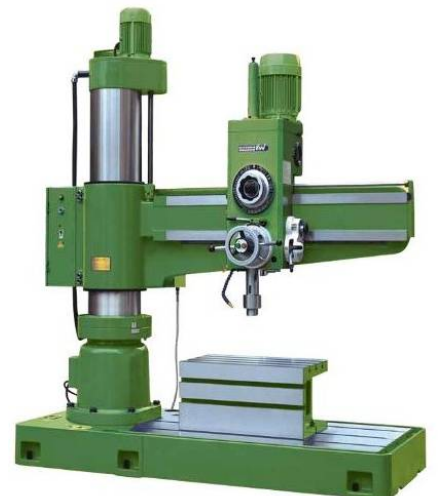

# NEW Kitchen & Walker G80 x 2500

## 1020607499N - Radial Drilling Machine

Radius Of Arm: 2500mm, Spindle Taper: MT6, Elevating Arm / Table / Portable / Unive: Elevating Arm, Spindle Speeds: 16-1250 rpm , Main Drive Power KW/V/Hz: 10 hp, Table Area: 630 x 500 x 500, Control: Power Feeds, Throat: 2500mm, Max Travel Of Drilling Head On Slide: 500-2500mm, Max Workpiece Height: 2000mm, Max Drilling Depth: 450mm, Feeds: 16, Maximum Drilling Capacity - Iron / Steel: 125mm / 80mm

£33,700

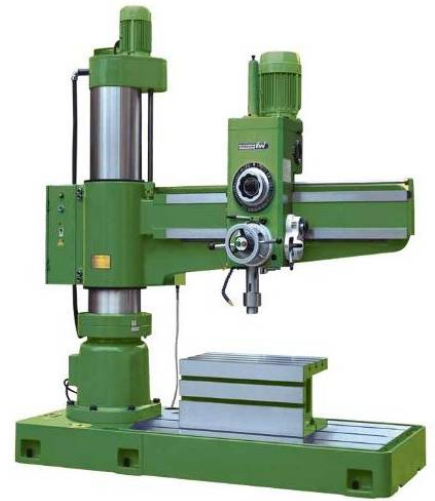

# NEW Chester KGS150

## 1505604430N - Surface Grinders

Working Surface of Table: 150 x 450mm, Max Table Travel: 483mm, Max Cross Travel: 178mm, Table & Spindle Centre Distance: 361mm, Max Table Load: 100kgs, No of T Slots: 1, Size of T Slots: 14mm, Cross Feed handwheel - 1 Grad: 0.01mm, Cross Feed Handwheel - 1 Rev: 2.5mm, Grinding Wheel: 180 x 13 x 31.75, Spindle Speed 50Hz: 2850 rpm, Vertical Handwheel - 1 Grad: 0.005mm, Vertical Handwheel - 1 Rev: 1.25mm, Spindle Motor: 1.1kw, Coolant Motor: 0.55kw, Dimensions: 1140 x 1060 x 1900mm, Weight: 560 kgs

£4,750



# NEW Chester KGS200

## 1505605704N - Surface Grinders - Hydraulic

Working surface of Table: 160 x 460mm, Max Table Travel: 495mm, Max Cross Travel: 220mm, Table / Spindle Centre Distance: 530mm, Max Table Load: 123 Kgs, No of T Slots: 1, Size of T Slots: 14mm, Crossfeed Handwheel 1 grad: 0.02mm, Crossfeed Handwheel - 1 rev: 5mm, Grinding Wheel: 200 x 25 x 31.75mm, Spindle Speed ( 50hz): 2850 rpm, Vertical Handwheel - 1 grad: 0.01mm, Vertical Handwheel - 1 Rev: 2mm, Spindle motor: 1.5Kw, Dust Collection Motor: 0.55Kw, Coolant Motor: 90w, Floor space: 1900 x 1900mm, Dimensions: 1120 x 1480 x 2090mm, Weight: 1100 Kgs

£6,700



# NEW Chester KGS818H

## 1505605705N - Surface Grinders - Hydraulic

Working surface of Table: 200 x 460mm, Maximum Grinding Dimension: 200 x 480mm, Max Table Travel: 510mm, Maximum Cross travel: 225mm, Table & Spindle Centre Distance: 530mm, Max Table Load: 150 kgs, No of T Slots: 1, Size of T Slot: 14mm, Crossfeed handwheel - 1 grad: 0.02mm, Crossfeed handwheel - 1 rev: 5mm, Grinding Wheel: 200 x 25 x 31.75mm, Spindle Speed (50hz): 2850 rpm, Vertical Handwheel - 1 Grad: 0.01, Vertical Handwheel - 1 Rev: 2mm, Spindle Motor: 1.5 Kw, Dust Collection Motor: 550w, Coolant motor: 90w, Floor Space: 2500 x 1900mm, Overall Dimensions: 2000x 1480 2090mm, Weight: 1200kgs

£11,300



# NEW Chester KGS818AH

## 1505605707N - Surface Grinders - Hydraulic

Working Surface of Table: 200 x 460mm, Max grinding Dimensions: 200 x 480mm, Max Table Travel: 510mm, Max Cross Travel: 225mm, Table & Spindle Centre distance: 530mm, Max Table Load: 150 kgs, Table Speed: 5 - 25m/min, No of T slots: 1, Size of T Slots: 14mm, Crossfeed Handwheel - 1 Grad: 0.02mm, Crossfeed Handwheel - 1 Rev: 5mm, Auto Cross feed of Saddle: 0 - 8.5mmmm, Grinding Wheel: 200 x 25 x 31.75mm, Spindle Speed (50Hz): 2850mm, Vertical handwheel - 1 grad: 0.01, Vertical Handwheel - 1 Rev: 2mm, Spindle Motor: 1.5kw, Hydraulic Motor: 1.5kw, Dust Collection Motor: 550w, Coolant Motor: 90w, Crossfeed Motor: 60w, Floor Space: 2500 x 1900mm, Overall dimensions: 2000 x 1480 x 2090mm, Weight: 1280kgs

£12,300



# NEW Chester KGS818AHR

## 1505605708N - Surface Grinders - Hydraulic

Working surface of Table: 200 x 460mm, Max Grinding Dimension: 200 x 480mm, Max Table Travel: 510mm, Max Cross Travel: 225mm, Table & Spindle Centre Distance: 530mm, Max Table Load: 150 kgs, Table Speed: 5 25m/min, No of T Slots: 1, Size of T Slots: 14mm, Crossfeed Handwheel - 1 Grad: 0.02mm, Crossfeed Handwheel - 1 Rev: 5mm, Auto crossfeed of Saddle: 0 - 8.5mm, Grinding Wheel: 200 x 25 x 31.75mm, Spindle Speed 50 hz: 2850 rpm, Vertical Handwheel - 1 grad: 0.01, Vertical Handwheel - 1 Rev: 2mm, Spindle Motor: 1.5 kw, Hydraulic Motor: 1.5kw, Dust collection Motor: 550 kw, Coolant Motor: 90w, Crossfeed Motor: 60w, Overall dimensions: 2000 x 1480 x 2090mm, Weight: 1280 kgs

£12,600



# NEW Chester KGS818AHD

## 1505605709N - Surface Grinders - Hydraulic

Working surface of Table: 200 x 460mm, Max Grinding Dimension: 200 x 480mm, Max Table Travel: 510mm, Max cross travel: 225mm, Table & spindle Centre distance: 530mm, Max Table Load: 150 kgs, Table speed: 5 - 25m/min, No of T Slots: 1, Size of T slots: 14mm, Crossfeed Handwheel - 1 Grad: 0.02mm, Crossfeed Handwheel - 1 Rev: 5mm, Auto Crossfeed of Saddle: 0 - 8.5mm, Grinding Wheel: 200 25 x 31.75mm, Spindle Speed (50Hz): 2850 rpm, Vertical hanwheel - 1 Grad: 0.01, Vertical Handwheel - 1 Rev: 2mm, Power Head Increment: 0.002 - 0.02mm, Spindle Motor: 1.5kw, Vertical Motor: 1.5kw, Hydraulic Motor: 1.5kw, Dust collection Motor: 550w, Coolant Motor: 90w, Crossfeed Motor: 60w, Floor space: 2500 x 1900mm, Weight / dimensions: 1320kgs / 2000 x 1480 x 2090mm



£13,900

---

# NEW Chester KGS1020

## 1505605710N - Surface Grinders - Hydraulic

Working Surface of Table: 250 x 510mm, Max Table Travel: 620mm, Max Cross Travel: 280mm, Table & Spindle Centre distance: 535mm, Max Table Load: 123 kgs, Table Speed: Manual, No of T Slot: 1, Size of T Slot: 14mm, Crossfeed Handwheel - 1 Grad: 0.02mm, Crossfeed Handwheel - 1 Rev: 5mm, Grinding Wheel: 200 x 25 x 31.75mm, Spindle Speed (50hz): 2850 rpm, Vertical Handwheel - 1 Grad: 0.01, Vertical Handwheel - 1 Rev: 2mm, Spindle Motor: 2.2kw, Dust Collection Motor: 550w, Coolant Motor: 90w, Dimensions: 1900 x 2300mm, Weight: 1480 kgs



£8,700

---

# NEW Chester KGS1020AH

## 1505605713N - Surface Grinders - Hydraulic

Working Surface of Table: 250 x 510mm, Max Table Travel: 575mm, Max Cross Travel: 280mm, Table & Spindle Centre distance: 530mm, Max Table Load: 300 kgs, Table Speed: 5.25m/min, No of T Slots: 1, Crossfeed Handwheel - 1 Grad: 0.02mm, Crossfeed Handwheel - 1 Rev: 5mm, Auto Crossfeed of Saddle: 0.5 - 12mm, Power Crossfeed 50hz: 790mm, Grinding Wheel: 200 x 25 x 31.75mm, Spindle Speed 50hz: 2850 rpm, Vertical handwheel - 1 Grad: 0.01, Vertical Handwheel - 1 Rev: 2mm, Auto Down feed Elevation: 0.002 - mm, Spindle motor: 2.2kw, Dust collection Motor: 500w, Hydraulic Motor: 1.5kw, Coolant Motor: 90w, Crossfeed Motor: 60w, Dimensions: 1650 x 2020 x 2140mm, Weight: 1655 kgs



£14,000

---

# NEW Chester KGS1020AHD

## 1505605715N - Surface Grinders - Hydraulic

Working Surface of Table: 250 x 510mm, Max Table Travel: 575mm, Max cross Travel: 280mm, Table & Spindle Centre distance: 530mm, Max table Load: 300kgs, Table speed: 5 - 25m/min, No of T Slots: 1, Size of T Slots: 14mm, Crossfeed Handwheel - 1 Grad: 0.02mm, Crossfeed Handwheel - 1 Rev: 5mm, Auto Crossfeed of Saddle: 0.5 - 12mm, Power Cross Feed 50 Hz: 790mm, Grinding Wheel: 200 x 25 x 31.75mm, Spindle Speed 50hz: 2850 rpm, Vertical Handwheel - 1 grad: 0.01, Vertical Handwheel - 1 Rev: 2mm, Auto Down Feed Elevation: 0.002 - 0.02mm, Spindle Motor: 2.2kw, Hydraulic Motor: 1.5kw, Dust Collection Motor: 500w, Coolant Motor: 90w, Crossfeed Motor: 60w, Overall Dimensions: 1650 x 2020 x 2140mm, Weight: 1655 kgs



£15,200

---

# NEW Chester KGS1224AH

## 1505605716N - Surface Grinders - Hydraulic

Table Working Surface: 300 x 600mm, Max Table Travel: 660mm, Max Cross Travel: 370mm, Table & spindle Centre distance: 540mm, Max Table Load: 420 kgs, Table Speed: 5.25m/min, No of T Slots: 1, Size of T Slots: 14mm, Crossfeed Handwheel - 1 Grad: 0.02mm, Crossfeed Handwheel - 1 Rev: 5mm, Auto Crossfeed of saddle: 0.5 - 12mm, Power Cross feed 50hz: 790mm/min, Grinding Wheel: 355 x 40 127mm, Spindle Speed 50hz: 1450 rpm, Vertical Handwheel - 1 Grad: 0.01, Vertical Handwheel - 1 Rev: 2mm, Spindle Motor: 4 kw, Hydraulic Motor: 1.5 kw, Dust Collection Motor: 550 kw, Coolant Motor: 90w, Crossfeed Motor: 90w, Dimensions: 2600 x 2500mm, Weight: 1850 kgs



£16,400

---

# NEW Chester KGS1224AHR

## 1505605717N - Surface Grinders - Hydraulic

Working Surface of Table: 300 x 600mm, Max Table Travel: 660mm, Max Coss Travel: 370mm, Table & Spindle Centre Distance: 540mm, Max Table Load: 420 kgs, Table Speed: 5.25m/min, No of T slots: 1, Size of T Slots: 14mm, Crossfeed Handwheel - 1Grad: 0.02mm, Crossfeed Handwheel - 1 Rev: 5mm, Auto Crossfeed of saddle: 0.5 - 12mm, Power Cross Feed 50hz: 790mm/min, Grinding Wheel: 355 x 40 x 127mm, Spindle Speed 50Hz: 1450 rpm, Vertical Handwheel - 1 grad: 0.01, Vertical Handwheel - 1 Rev: 2mm, Power Head Increment: 380mm, Spindle Motor: 4kw, Vertical Motor: 0.90kw, Hydraulic Motor: 1.5kw, Dust Collection Motor: 550w, Coolant Motor: 90w, Crossfeed Motor: 90w, Dimensions: 2090 x 1940 x 2210mm, Weight: 1810 kgs



£16,800

---

# NEW Chester KGS1224AHD

## 1505605718N - Surface Grinders - Hydraulic

Working surface of table: 300 x 600mm, Max Table Travel: 660mm, Max Cross Travel: 370mm, Table & Spindle Centre Distance: 540mm, Max Table Load: 420 kgs, Table Speed: 5.25m/min, No of T Slots: 1, Size of T Slots: 14mm, Crossfeed Handwheel - 1 Grad: 0.02mm, Crossfeed Handwheel - 1 - Rev: 5mm, Auto Crossfeed of saddle: 0.5 - 12mm, Power CrossFeed 50hz: 790mm/min, Grinding wheel: 355 x 40 x 127mm, Spindle Speed 50hz: 1450 rpm, Vertical handwheel - 1 Grad: 0.0001mm, Vertical handwheel - 1 Rev: 0.5mm, Auto Down Feed Elevation: 0.005 - 0.025mm, Power Head Increment: 230mm, Spindle Motor: 4kw, Vertical Motor: 0.90kw, Hydraulic Motor: 1.5 kw, Dust Collection Motor: 550w, Coolant Motor: 90w, Crossfeed Motor: 90w, Weight/Dimensions: 1910kgs/ 2090 x 1940 x 2210mm



£18,700

---

# NEW Chester KGS1632AH

## 1505605719N - Surface Grinders - Hydraulic

Working surface of Table: 400 x 800mm, Max Table Travel: 920mm, Max Cross Travel: 450mm, Table & Spindle Centre Distance: 580mm, Max Table Load: 700kgs, Table speed: 5-25m/min, No of T Slots: 3, Size of T Slots: 14mm, Crossfeed Handwheel - 1 Grad: 0.02mm, Crossfeed Handwheel - 1 Rev: 5mm, Auto Crossfeed of Saddle: 0.5 - 12mm, Power Cross Feed 50Hz: 790mm/min, Grinding Wheel: 355 x 40 127mm, Spindle Speed 50Hz: 1450 rpm, Vertical Handwheel - 1 Grad: 0.01mm, Vertical Handwheel - 1 Rev: 2mm, Spindle Motor: 5.5kw, Hydraulic Motor: 2.2kw, Dust Collection Motor: 550mm, Coolant Motor: 90w, Crossfeed Motor: 90w, Dimensions: 2775 x 2255 x 2210mm



£22,400

---

# NEW Chester KGS1632AHR

## 1505605720N - Surface Grinders - Hydraulic

Working Surface of Table: 400 x 800mm, Max Table Travel: 920mm, Max Cross Travel: 450mm, Table & spindle Centre Distance: 580mm, Max Table Load: 700 kgs, Table Speed: 5 - 25m/min, No of T Slots: 3, Size of T Slots: 14mm, Cross Feed Handwheel - 1 Grad: 0.02mm, Cross Feed Handwheel - 1 Rev: 5mm, Auto Crossfeed of Saddle: 0.5 - 12mm, Power Cross Feed 50hz: 790mm/min, Grinding Wheel: 355 x 40 x 127mm, Spindle Speed 50hz: 1450 rpm, Vertical Handwheel - 1 Grad: 0.01mm, Vertical Handwheel - 1 Rev: 2mm, Power Head Increment: 380mm, Spindle Motor: 5.5 kw, Vertical Motor: 90w, Hydraulic Motor: 2.2 kw, Dust Collection Motor: 550w, Coolant Motor: 90w, Crossfeed Motor: 90w, Dimensions: 2775 x 255 x 2210mm



£25,500

---

# NEW Chester KGS1640AH

## 1505605721N - Surface Grinders - Hydraulic

Working Surface of Table: 400 1000mm, Max Table Travel: 1120mm, Max Cross Travel: 450mm, Table & Spindle Centre Distance: 580mm, Max Table Load: 700kgs, Table Speed: 5 - 25mm/min, No of T Slots: 3, Size of T Slots: 14mm, Crossfeed Handwheel - 1 Grad: 0.02mm, Crossfeed Handwheel - 1 Rev: 5mm, Auto Crossfeed of Saddle: 0.5 - 12mm, Power Crossfeed 50hz: 790mm/min, Grinding Wheel: 355 x 40 x 127mm, Spindle Speed 50hz: 1450 rpm, Vertical Handwheel - 1 Grad: 0.01mm, Vertical Handwheel - 1 Rev: 2mm, Spindle Motor: 5.5kw, Hydraulic Motor: 2.2kw, Dust Collection Motor: 500w, Coolant Motor: 90w, Crossfeed Motor: 90w, Dimensions: 2990 x 2225 x 2210mm

£23,900



# NEW Chester KGS1632AHD

## 1505605774N - Grinder - Hydraulic

Max Grinding Wheel Dia X Width: 355x40x127mm, Grinding Wheel Speeds: 1450 rpm, Max Table Travel Longitudinal / Cross: 920x450mm, Table Size: 400x800mm, Dust Extractor: Yes, Magnetic Clamping Plate: Yes, Coolant: Yes, Power Supply: 415/3phase/50hz, Motor rating: 5.5kw, Vertical Handwheel - 1 Rev: 2mm, Vertical Handwheel - 1 Grad: 0.01mm

£24,200



# NEW Chester KGS1640AHD

## 1505605776N - Grinder - Hydraulic Surface

Working surface of table: 400mm x 1000mm, Maximum table travel: 1120mm, Maximum cross travel: 920mm, Distance between table & spindle centre: 580mm, Maximum table load: 700kgs, Table speed: 5-25mm/min, No of T slots & Size: 3 - 14mm, Crossfeed Handwheel - 1 Grad: 0.02mm, Crossfeed handwheel - 1 Rev: 5mm, Automatic crossfeed of saddle: 0.5 - 12mm, Power cross feed - 50hz: 1450rpm, Vertical handwheel - 1 Grad: 0.001mm, Vertical Handwheel - 1 Rev: 0.5mm, Auto downfeed elevation: 0.025mm, Power head increment: 230, Spindle motor: 5.5Kw, Hydraulic Motor: 2.2Kw, Dust Collection motor: 550w, Coolant motor: 550w, Cross feed motor: 90w, Floor space: 3600 x 2600mm

£26,900



# NEW Chester KGS1640AHR

## 1505607502N - Grinder - Hydraulic Surface

Working surface of table: 400mm x 1000mm, Maximum table travel: 1120mm, Maximum cross travel: 450mm, Distance between table & spindle centre: 580mm, Maximum table load: 700kgs, Table speed: 5-25mm/min, No of T slots & Size: 3 - 14mm, Crossfeed Handwheel - 1 Grad: 0.02mm, Crossfeed handwheel - 1 Rev: 5mm, Automatic crossfeed of saddle: 0.5 - 12mm, Power cross feed - 50hz: 790mm/min, Vertical handwheel - 1 Grad: 0.001mm, Vertical Handwheel - 1 Rev: 0.5mm, Spindle motor: 5.5Kw, Hydraulic Motor: 2.2Kw, Dust Collection motor: 550w, Coolant motor: 550w, Cross feed motor: 90w, Floor space: 3600 x 2600mm, Spindle speed 50hz: 1450 rpm

£24,300

---

# NEW Chester Unigrind CG250

## 1510004432N - Tool & Cutter Grinder

X/Y/Z Travel: 200 swing over table / 125 x 300 Surface, Max Grinding Diameter X Length: 200 x 500, Max Grinding Wheel Diameter X Length: 250 x 20 x 75, Max Workpiece Weight: 10kg, Grinding Wheel Speeds: Wheelhead 2500rpm / internal 13500rpm, Feeds: 0.01/0.005, Power Capacity: 2.9

£13,215



# NEW Chester Unitool

## 1510004433N - Tool & Cutter Grinder

X/Y/Z Travel: 200 swing over table / 125 x 300 Surface, Max Grinding Diameter X Length: 200 x 500, Max Grinding Wheel Diameter X Length: 250 x 20 x 75, Max Workpiece Weight: 10kg, Grinding Wheel Speeds: Wheelhead 2500rpm / internal 13500rpm, Feeds: 0.01/0.005, Power Capacity: 2.9

£3,500



## NEW Chester TC2

### 1510004434N - Tool & Cutter Grinder

Air bearing stroke: 250mm, Swing over Table: 245mm, Cutting Tool Cap: 50mm shank, 225mm OD, 250mm long, Long. Travel: 150mm, Cross Wheel Travel: 75mm, Speed: 3450rpm

£1,590



## NEW Chester Unigrind CG200

### 1510005703N - Tool & Cutter Grinder

Max swing over table: 200mm, Max workpiece length: 500mm, External grinding sizes: 5.50mm x 400, Internal grinding sizes: 10.50 x 75mm, Surface Grinding: 125 x 300mm, Max Weight of Work: 10 kgs, Workhead spindle Speeds: 110, 200, 300 rpm, Workhead swivel: + or - 90 degrees, Max Travel of workhead: 200mm, Wheelhead Reed Vertical x Cross: 0.01 / 0.005, Wheelhead Speed: 2500 rpm, Wheel Swivel: + or - 90 degrees, Internal Spindle Speed: 13500 rpm, Size of Grinding Wheel Ext: 200 x 20 x 75mm, Size of grinding wheel Int: 10 x 10 x 3mm, Longitudinal Travel (Manual): 500mm, Longitudinal Travel (Hydraulic): 400mm, Table traverse speed: 7m/min, Table Swivel: +45 / -30 degrees, Total Motor Rating: 2.9 Kw, Weight: 1285 Kgs, Dimensions: 1526 x 1133 x 1173mm



£11,115

## NEW Chester TC2

### 1510005775N - Grinder - Tool & Cutter Grinder

Air bearing stroke: 250mm, Swing over table: 245mm, Cutting tool Capacity: 50mm Shank-225mmOD - 250mm Length, Table feed graduations: 0.02mm, T slot size: 12mm, Swivel adjustment of table: 15 degrees, Longitudinal travel: 150mm, Cross travel - Wheel table: 75mm, Max motor assembly travel across table: 150mm, Maximum wheel size: 125 x 50 x 31.75mm cup, Tilt adjustment of wheel head: +30 to 15 degrees, Wheel speed: 3450 rpm, Motor: 3/4 hp, Weight: 106 kgs, Dimensions: 535 x 500 x 535mm

£1,590



## NEW Chester UG20 x 500

### 1515004431N - Universal Cylindrical Grinder

Distance between Centres: 500 mm, Centre height: 135 mm, Wheel Spindle speed: 1670 rpm, Tailstock: MT 4, Max weight of workpiece: 100 Kgs, Wheel Size: 400 x 203 x 50 mm, Internal Spindle Capacity Dia x Length: 25 - 100 x 100 mm, Outside Dia Capacity: 5 - 200 mm

£18,200

---



## NEW Chester UG20 x 700

### 1515007021N - Universal Cylindrical Grinder

Distance between Centres: 750mm, Centre height: 135mm, Wheel Spindle speed: 1670 rpm, Tailstock: 4 MT, Max weight of workpiece: 100 kgs, Wheel Size: 400 x 203 x 50 mm, Internal Spindle Capacity dia x length: 25 - 100 mm x 100mm, Outside Dia Capacity: 5 - 200 mm

£19,100

---

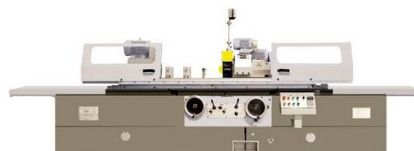

## NEW Chester UG32 x 1000

### 1515007022N - Universal Cylindrical Grinder

Distance between Centres: 1000 mm, Centre height: 180 mm, Wheel Spindle speed: 1670 rpm, Tailstock: 4 MT, Max weight of workpiece: 150 kgs, Wheel Size: 400 x 203 x 50 mm, Internal Spindle Capacity dia x length: 30-100 x 125 mm, Outside Dia Capacity: 8-320 mm

£22,100

---

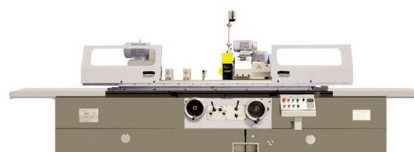

## NEW Chester UG32 x 1500

### 1515007023N - Universal Cylindrical Grinder

Distance between Centres: 1500 mm, Centre height: 180 mm, Wheel Spindle speed: 1670 rpm, Tailstock: 4 MT, Max weight of workpiece: 150 kgs, Wheel Size: 400 x 203 x 50 mm, Internal Spindle Capacity dia x length: 30-100 x 125 mm, Outside Dia Capacity: 8-320 mm

£24,700

---

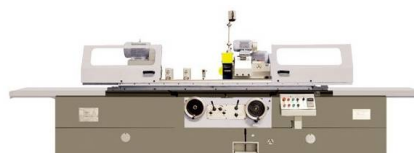

## NEW Brierley ZB32

### 1525305696N - Grinder - Drill Point

Drill Size Diameters (Straight or Taper): 1.5 - 32mm, Point Angle: 40 - 180 degrees, Clearance Angle: 0 - 18 degrees, Workhead Tilting Angle: 0 - 20 degrees, Brake Motor: 1/2 HP, Grinding Wheels: 180 x 20 x 31.75mm, Dish Wheels: 165 x 21 x 31.75mm, Net weight: 120 kilos, Dimensions: 820 x 790 x 740mm

£6,800



## NEW Brierley ZB50

### 1525305697N - Grinder - Drill Point

Drill Size - Straight: 0.25mm - 51mm, Drill Size - Taper Shank: 1 to 6 flute, Point Angles: 40 - 180 degrees, Clearance Angle: 0 - 18 degrees, Motor: 1/2 HP Single or 3 Phase, Grinding Wheel (Main): 180 x 32 x 31.75mm, Point Thinning Dish Wheel: 165 x 21 x 31.75mm, End Grinding of End Mills: 2,3,4,6 & 12, Weight: 300 kgs, Dimensions: 970 x 910 x 1600mm

£10,200



## NEW Brierley ZB80

### 1525305698N - Grinder - Drill Point

Drill Size: 4 to 80mm (1 to 6 flute), Point Angles: 40 - 180 degrees, Clearance Angle: 0 - 18 Degrees, Motor: 1 1/2 Hp, Grinding Wheel Main: 180 x 50 x 31.75mm, Point Thinning Dish Wheel: 165 x 21 x 31.75mm, End Grinding of End Mills: 2,3,4,6,12 flute, Weight: 380 Kgs, Dimensions: 1090 x 1120 x 1650mm

£11,200



## NEW Brierley ZB160

### 1525305699N - Grinder - Drill Point

Tool Diameter: 2 - 200mm, Spiral Length with workhead spindle: 160mm, Longitudinal Travel of Workhead: 280mm, Cross Travel of Workhead: 130mm, Rapid cross move with hand lever: 18mm, Vertical Movement of Wheel Head: 230mm, Tilting Angle of Wheel Head: 0 - 30 degrees, Workhead spindle: ISO 40, Helix Angle: 0 - 90 degrees, Grinding Wheel diameter: Max 150mm - Grinding wheel bore 31.75mm, Grinding motor: 0.75 Kw, Grinding Wheel Direction: Clock or anti-clockwise, Grinding Spindle Speeds: 6300, 3800, 2600 rpm, Weight: 540 kgs, Dimensions: 1480 x 1120 x 1640mm

£24,400



## NEW Chester Brierley 13X

### 1525305700N - Grinder - Drill Point

Drill Size: 3 to 13mm diameter, Point angle: 118 - 135 degrees, Power supply: Single Phase 110vac 220v, Motor: 1/4 hp - 180W, Motor Speed: 5300 rpm, Diamond Grinding Wheel: CBN#200, Weight: 10 kgs, Packing dimensions: 310 x 170 x 190mm

£550



## NEW Chester Brierley 26X

### 1525305701N - Grinder - Drill Point

Drill Size: 12 - 26mm, Point angle: 100 - 135 Degrees, Power Supply: 220 volt single phase, Motor: 1/4 hp - 180w, Motor Speed: 5300 rpm, Diamond Grinding Wheel: CBN#200, Weight: 24 kgs, Packing dimensions: 460 x 240 x 220mm

£1,260



## NEW Chester Neptune

### 1525305702N - Grinder - End Mill

Capacity: 4 - 13mm, Motor Power: 450w, Wheel Speed: 6000 rpm, Power Supply: 240v single phase, Slot Angle: 30 degrees, Radial Angle: 20 degrees, Grinding Angles: 30, 20 or 6 degrees, Weight: 17 kgs, Packing dimensions: 320 x 260 x 300mm

£1,020



## NEW Chester TG8 -100

### 1545004334N - Double Ended Grinder with Linisher & Grinding Wheel

Grinding Height (mm): 895m/min, Grinding Wheel Diameter (mm): 200, Dimension Of Workpiece (mm): 100, Workpiece Height (mm): 190, Grinding Speed: 2850 rpm, Distance Between The Grinding Wheels (mm): 390, Power: 415 V / 3-phase

£320



## NEW Chester SG6

### 1545005722N - Grinder - Double Ended Bench Model

Main power supply: 110v single phase or 240 Single phase, Motor Power: 1/3 Hp - 0.15Kw, Wheel Diameter: 150 x 25 x 20mm, Distance between wheels (mm): 305mm, Wheel Speed: 2850 rpm, Dimensions: 370 x 215 x 270mm, Weight: 11.5 kgs

£130



## NEW Chester SG8

### 1545005723N - Grinder - Double Ended Bench Model

Main power supply: 110volt / 240volt single phase, Grinding Wheel Speeds (Rpm): 2850 rpm, Grinding Wheel Diameter (mm): 200 x 25 x 20mm, Distance between wheels (mm): 390mm, Dimensions: 470 x 265 x 300mm, Weight: 19.5 kgs, Stand : Extra

£440



## NEW Chester SG10

### 1545005726N - Grinder - Double Ended Bench Model

Main Power supply: 240volt/ 1 phase, Grinding Wheel Speeds (Rpm): 2850 rpm, Grinding Wheel Diameter (mm): 250 x 38 x 25.4mm, Distance between wheels (mm): 470mm, Dimensions: 580 x 350 x 350mm, Weight: 47 kilos, Stand: Extra

£380



## NEW Chester TG12

### 1545005727N - Grinder - Double Ended Bench Model

Main Power Supply: 415volt/ 3 phase, Grinding Wheel Speeds (Rpm): 1420, Grinding Wheel Diameter (mm): 300 x 50 x 20, Distance between wheels (mm): 570, Dimensions: 740 x 490 x 395mm, Weight: 82 kilos

£620



## NEW Chester TG10

### 1545007503N - Grinder - Double Ended Bench Model

Main Power supply: 415 volts/3 phase, Grinding Wheel Speeds (Rpm): 2850 rpm, Grinding Wheel Diameter (mm): 250 x 39 x 25.4mm, Distance between wheels (mm): 470mm, Dimensions: 580 x 350 x 350mm, Weight: 47 Kgs

£370

## NEW Chester 1X5

### 1550305219N - Belt & Disc Sander.

Band Width (mm): 25, Band Length (mm): 762, Band Speed: 16.4m/s, Power: 240v/300w,  
Belt Dimensions: 25 x 762mm, Disc Speed: 3400r/min

£60



## NEW Chester TG100

### 1550305730N - Grinder - Belt

Wheel size: 200 x 25 x 20mm, Belt size: 100 x 1000mm, Motor Power: 0.7hp - 0.55Kw,  
Power supply: 415 Volt - 3 phase, Wheel Speed: 2850 rpm, Belt Speed: 15m/Sec, Flat  
Grinding Surface: 100 x 250mm, Guard Thickness: 2.5mm, Dimensions: 510 x 265 x  
630mm

£400



## NEW Chester SG6-50

### 1550305731N - Grinder - Belt

Wheel Size: 150 x 25 x 20mm, Belt Size: 100 x 1000mm, Motor Power: 0.4hp - 0.2kw,  
Power Supply: 240volt/ 1 phase, Wheel Speed: 2850 rpm, Belt Speed: 15m/Sec, Flat  
Grinding Surface: 50 x 250mm, Guard Thickness: 2.5mm, Dimensions: 395 x 215 x  
590mm, Weight: 16.5 Kg

£270



## NEW Chester SB100/240

### 1550305779N - Belt Finishing Grinder

Band Width: 100mm, Band Length: 1220mm, Band Speed: 19m/sec, Motor power: 1 hp - 0.75kw, Power supply: 240vlt, Flat grinding surface: 320 x 105mm, Guard Thickness: 2.5mm, Dimensions: 650x380x260mm, Weight: 27kgs, Stand: extra

£480



## NEW Kepp 150

### 1550604050N - Belt Grinder - Pedestal

Band Width (mm): 150, Band Length (mm): 2000, Band Speed (mm/S): 37, Main Drive Power (KW/V/Hz): 3.6/415Volts/3ph/50hz

£1,245



## NEW Chester TB100

### 1550604343N - Belt Grinder - Pedestal

Band Width (mm): 100mm, Band Length (mm): 1500mm, Band Speed (mm/S): 19m/sec, Main Drive Power (KW/V/Hz): 2 hp / 415v / 1.5kw, Flat Grinding Surface: 320 x 105, Electrics: 415 volts 3phase, Dust Extraction: Available as optional extra

£840



## NEW Chester SAND-12

### 1550605248N - Disc Sander

Main Drive Power (KW/V/Hz): 240v/750w, Table Tilt: 45 degrees, Wheel Speed: 1450 rpm

£120



## NEW Chester SAND-BD46A

### 1550605249N - Belt & Disc Sander.

Main Drive Power (KW/V/Hz): 240v/370w, Speed: 2850 rpm, Disc Size: 6"

£90



## NEW Chester 612 Grinder

### 1580005217N - Surface Grinder

Table-Size (mm): 152 x 304mm, Wheel Dimensions: 180 x 32 x 13mm, Power supply: 240v, Motor Power: 3/4 hp, Grinding Height: 210mm, Dimensions: 930 x 780 x 730mm, Weight: 210 Kgs

£2,099



## NEW Chester SP7

### 1580005728N - Polisher - Double Ended (Stand Extra)

Mop Size: 175 x 25 x 20mm, Motor power: 3/4 hp - 0.55 Kw, Power supply: 240 volt/ single phase, Wheel speed: 2850 rpm, Guard Thickness: 2.5mm, Distance Between Wheels: 390mm, Dimensions: 470 x 265 x 300mm, Weight: 19.5 kgs

£200



## NEW Chester TP7/415

### 1580005780N - Polisher - Double Ended (Stand Extra)

Mop size: 175 x 25 x 20mm, Motor power: 3/4hp - 0.55Kw, Power supply: 415v, Wheel speed: 2850rpm, Guard Thickness: 2.5mm, Distance between wheels: 390mm, dimensions: 470 x 265 x 300mm, Weight: 19.5kgs

£200



## NEW Metosa Pinacho Extensive Range of

### 2015604058N - Electronic CNC Lathes

Turning Diameter (mm): 300 to 610mm, Turning Length (mm): 1000 to 3000mm, Control Type: Fagor or Fanuc Conversational, Number Of Controlled Axis: 2, Tailstock: Manual or Hydraulic, Chuck: Manual or Hydraulic, Toolpost: Manual or Turret



## NEW Powercentre 1440NC

### 2015607142N - Lathe - CNC Electronic

Turning Diameter (mm): 350mm / 14", Turning Length (mm): 1000mm / 40", Toolpost: 4 way Electronic Indexing, Control Type: Siemens 808D, Number Of Controlled Axis: 2, Spindle Bore (mm): 38mm, Main Drive Power (KW/V/Hz): 5hp , Tailstock: Manual, Chucking Diameter (mm): 6" 3 jaw, Spindle Turning Speed Range: 30-2000rpm, Feeds: 6m/min, Tailstock: MT3

£22,500



# NEW Powercentre 1760NC

## 2015607143N - Lathe - CNC Electronic

Turning Diameter (mm): 440mm / 17", Turning Length (mm): 1500mm / 60", Toolpost: 4 way Electronic Indexing, Control Type: Siemens 808D, Number Of Controlled Axis: 2, Spindle Bore (mm): 86mm, Main Drive Power (KW/V/Hz): 10hp , Tailstock: Manual, Chucking Diameter (mm): 10" 3 jaw, Spindle Turning Speed Range: 10-2000rpm, Feeds: 8m/min, Tailstock: MT5

£23,750



# NEW Chester Cobra

## 2020004786N - Centre Lathe

Centre height: 70mm, Max Swing: 140mm, Distance between centre: 250mm, Spindle Bore: 9mm, Speeds: Variable 100- 2000 rpm, Metric Threads - Metric Machine: 0.5 - 1.25mm, Imperial Threads: 16-24 TPI, Tailstock Quill Travel: 25mm, Crossslide travel: 60mm, Motor: 150W

£435

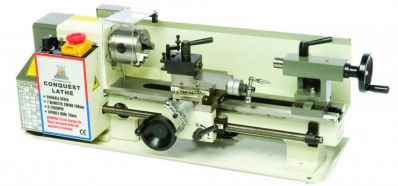

# NEW Chester Comet

## 2020005778N - Centre Lathe

Centre height: 105mm, Maximum swing: 210mm, Distance between centres: 450mm, Spindle bore: 20mm, Spindle speeds: 100-2000rpm, Range of metric threads: 0.25 - 3mm, Range of imperial threads: 8-24tpi, Longitudinal feed rate (mm): 0.07mm/r, Cross slide feed rate (min): 0.2mm/r, Tailstock taper: MT2, Motor: 1.5hp, Power: 240volt, Dimensions: 1000x550x400mm, Net weight: 94kgs

£1,269



# NEW Chester DB10 Super B Lathe

## 2025304885N - Centre Lathe

Spindle Turning Speed Range: Var, Spindle Bore (mm): 21, Main Drive Power (KW/V/Hz): 3/4 hp, Turning Diameter Over Bed (mm): 250, Center Distance (mm): 550, 3 Jaw & 4 jaw Chucks: yes, Accessories: F & T steadies, 3 & 4 jaw chucks.

£1,270



# NEW Chester DB11GVS

## 2025304886N - Centre Lathe

Spindle Bore (mm): 26mm, Main Drive Power (KW/V/Hz): 240volts/1 phase/50hz., Turning Diameter Over Bed (mm): 280mm, Turning Diameter Over Slide (mm): 145mm, Center Distance (mm): 700mm, Taper of Spindle Bore: MT4, Number of spindle Speeds: Variable, Range of spindle speeds: 125 - 2500 rpm, Range of inch threads: 8 to 56 tpi, Range of Metric Threads: 0.2 to 3.5mm, Top slide travel: 50mm, Cross Slide travel: 115mm, Tailstock Quill Travel: 70mm, Taper of Tailstock Quill: MT2, Motor rating: 1 HP, Net weight: 180 kilos, Dimensions: 1390 x 700 x 630mm

£1,640



# NEW Chester Craftsman

## 2025304889N - Centre Lathe

Spindle Turning Speed Range: 50-1200rpm, Spindle Bore (mm): 36, Main Drive Power (KW/V/Hz): 1.5hp, Turning Diameter Over Bed (mm): 300, Turning Diameter Over Slide (mm): 200, Max. Swing-Dia. In Gap (mm): 450, Center Distance (mm): 570, 3 Jaw & 4 jaw Chucks: yes, Accessories: F & T steadies, FP, centres, guards, Gross weight: 390 kgs

£2,340



# NEW Chester Crusader

## 2025305070N - Centre Lathe

Spindle Turning Speed Range: 75-1400, Spindle Bore (mm): 38, Main Drive Power (KW/V/Hz): 1.5hp, Turning Diameter Over Bed (mm): 300, Turning Diameter Over Slide (mm): 178, Max. Swing-Dia. In Gap (mm): 430, Center Distance (mm): 150, DRO: Optional Extra, 3 Jaw Chuck: Yes, QCTP: Optional, Lo Volt Light: Yes

£2,490



# NEW Chester Crusader Deluxe

## 2025307220N - Centre Lathe

Spindle Turning Speed Range: 65-1810 rpm, Spindle Bore (mm): 38, Main Drive Power (KW/V/Hz): 1.13kw / 1.5hp, Turning Diameter Over Bed (mm): 300, Turning Diameter Over Slide (mm): 178, Max. Swing-Dia. In Gap (mm): 430, Center Distance (mm): 810, DRO: Yes, 2 axis, 3 Jaw & 4 jaw Chucks: Yes, QCTP: Yes, Lo Volt Light: Yes, Spindle Nose: MT5 / D1-4, Tailstock taper: MT3, Tailstock quill travel: 100mm

£5,000



# NEW Chester Crusader Lat Crus VS1

## 2025307221N - Centre Lathe Variable Speed

Spindle Turning Speed Range: 70-2000 rpm, Spindle Bore (mm): 51, Main Drive Power (KW/V/Hz): 1.5kw / 2hp, Turning Diameter Over Bed (mm): 330, Turning Diameter Over Slide (mm): 224, Max. Swing-Dia. In Gap (mm): 476, Center Distance (mm): 750, DRO: Yes, 2 axis, 3 Jaw & 4 jaw Chucks: Yes, QCTP: Yes, Lo Volt Light: Yes

£4,400



# NEW Chester Crusader Lat Crus VS4

## 2025307222N - Centre Lathe Variable Speed

Spindle Turning Speed Range: 70-2000 rpm, Spindle Bore (mm): 51, Main Drive Power (KW/V/Hz): 1.5kw / 2hp, Turning Diameter Over Bed (mm): 356, Turning Diameter Over Slide (mm): 250, Max. Swing-Dia. In Gap (mm): 502, Center Distance (mm): 1000, DRO: Yes, 2 axis, 3 Jaw & 4 jaw Chucks: Yes, QCTP: Yes, Lo Volt Light: Yes

£4,500



# NEW Chester Chieftain 1640

## 2025604323N - Centre Lathe with Digital Readout

Distance between Centres: 1000mm, Centre height: 210mm, Maximum Swing: 425mm, Swing over Cross Slide: 250mm, Swing in Gap: 640mm, Length in Gap: 310mm, Bed width: 340mm, Spindle Bore: 80mm, Spindle Taper: MT7, Spindle Nose - Camlock: D1-8, Tailstock Quill Diameter: 75mm, Tailstock Taper: MT4, Cross Slide Travel: 275mm, Compound Slide Travel: 140mm, Max Tool Size: 25mm, Number of Speeds: 12, Range of Speeds: 25-1800rpm, Leadscrew Pitch: 6mm, Cross Screw Pitch: 4mm, Motor: 7.5 hp, Power Supply: 415v, Net Weight: 2488 kgs, Dimensions: 2300 x 1000 x 1320mm

£18,000



# NEW Chester Chieftain 1860

## 2025605599N - Centre Lathe with Digital Readout

Centre Height: 230mm, Distance between Centres: 1500mm, Max Swing: 460mm, Swing in Gap: 700mm, Bore: 80mm, Spindle Nose: D1-8", Speeds: 25-1800 rpm, Motor: 7.5hp

£20,000



## NEW Chester Chieftain 1660

### 2025605737N - Centre Lathe with Digital Readout

Distance Between centres: 1500mm, Centre Height: 210mm, Maximum Swing: 425mm, Swing Over Crossslide: 250mm, Swing in Gap: 640mm, Length in gap: 640mm, Bed width: 340mm, Spindle Bore: 80mm, Tailstock: MT4, Number of Speeds: 12, Range of Speeds: 25 - 1800 rpm, Motor: 7.5 hp, Power supply: 415volts/ 3 phase, Weight: 2488 kgs, Dimensions: 2800 x 1000 x 1320 kgs

£19,000



## NEW Chester Chieftain 1840

### 2025605738N - Centre Lathe with Digital Readout

Centre Height: 230mm, Distance between Centres: 1000mm, Max Swing: 460mm, Swing in Gap: 700mm, Bore: 80mm, Spindle Nose: D1-8", Speeds: 25-1800 rpm, Motor: 7.5hp

£12,600



## NEW Chester Chieftain 1880

### 2025605739N - Centre Lathe with Digital Readout

Centre Height: 230mm, Distance between Centres: 2000mm, Max Swing: 460mm, Swing in Gap: 700mm, Bore: 80mm, Spindle Nose: D1-8", Speeds: 25-1800 rpm, Motor: 7.5hp

£22,000



## NEW Chester Chieftain 2640

### 2025605740N - Centre Lathe with Digital Readout

Centre Height: 330mm, Distance between Centres: 1000mm, Max Swing: 660mm, Swing in Gap: 870mm, Bore: 105mm, Spindle Nose: D1-8, Speeds: 36 - 1600 rpm, Motor: 10 hp, Power Supply: 415v / 3 phase, Weight: 2500 kilos, Dimensions: 2500 x 1000 1450mm

£24,000



## NEW Chester Chieftain 2660

### 2025605741N - Centre Lathe with Digital Readout

Centre Height: 330mm, Distance between Centres: 150mm, Max Swing: 660mm, Swing in Gap: 870mm, Bore: 105mm, Spindle Nose: D1-8 Camlock, Speeds: 36 - 1600 rpm, Motor: 10 hp, Power supply: 415volts, Dimensions: 3000 x 1100 x 1450mm, weight: 2700 kilos

£25,000



## NEW Chester Chieftain 2680

### 2025605742N - Centre Lathe with Digital Readout

Centre Height: 330mm, Distance between Centres: 2000mm, Max Swing: 660mm, Swing in Gap: 870mm, Bore: 105mm, Spindle Nose: D1-8 Camlock, Speeds: 36 - 1600 rpm, Motor: 10 hp, Power supply: 415volts/ 3 phase, Dimensions: 3500 x 1100 1450mm, Weight: 3000 kgs

£27,000



## NEW Chester Challenger

### 2025605800N - Centre Lathe with Digital Readout

Turning Diameter Over Bed (mm): 356mm, Turning Diameter Over Slide (mm): 200mm, Center Distance (mm): 175mm, Spindle Bore (mm): 38mm, Main Drive Power (KW/V/Hz): 415V, Turning Length (mm): 750mm, Spindle Turning Speed Range: 45 to 1800rpm, Feeds - Longitudinal: 0.043 - 0.653mm/rev, Feeds - Cross: 0.015 - 0.220mm/rev, Max. Swing-Dia. In Gap (mm): 506mm, Number Of Controlled Axis: 2 Axis DRO, Tailstock Spindle Travel: 125mm, Headstock Spindle Taper: MT5, Tailstock Spindle Taper: MT3, Motor: 3hp

£6,300



## NEW Chester Coventry Deluxe

### 2025606816N - Centre Lathe

Swing over bed: 330mm, Swing over crossslide: 198 mm, Swing in Gap: 476 mm, Centre height: 165 mm, Distance between centres: 500 mm, Bed width: 186 mm, Motor: 2hp / 240v / 415v, Spindle bore: 38mm, Spindle Mount: MT5, Spindle speeds: 70-2000 rpm, Imperial Threads: 3 1/2 80-tpi / 38 step, Metric threads: 0.45-10mm / 23 step, Tailstock taper: MT3, Net weight: 430/475/524 kgs, DRO: 2 axis

£5,300



# NEW Chester Voyager

## 2025607041N - Centre Lathe

Swing over bed: 356mm, Swing over carriage: 210 mm, Swing in Gap: 508 mm, Centre height: 178 mm, Distance between centres: 1000mm, Bed width: 260 mm, Motor: 3hp , Spindle bore: 40mm, Spindle Mount: MT3, Spindle speeds: 40-1800 rpm, Imperial Threads: 4-56-tpi / 56 step & 4-112tpi, Metric threads: 0.45-7mm / 28 step, Tailstock taper: MT3, Net weight: 1200kg, DRO: 2 axis

£6,700



# NEW Chester Coventry Deluxe

## 2025607084N - Centre Lathe

Swing over bed: 330mm, Swing over crossslide: 198 mm, Swing in Gap: 476 mm, Centre height: 165 mm, Distance between centres: 750 mm, Bed width: 186 mm, Motor: 2hp / 240v / 415v, Spindle bore: 38mm, Spindle Mount: MT5, Spindle speeds: 70-2000 rpm, Imperial Threads: 3 1/2 80-tpi / 38 step, Metric threads: 0.45-10mm / 23 step, Tailstock taper: MT3, Net weight: 430/475/524 kgs, DRO: 2 axis

£5,300



# NEW Chester Coventry Pro

## 2025607085N - Centre Lathe

Swing over bed: 330mm, Swing over crossslide: 198 mm, Swing in Gap: 476 mm, Centre height: 165 mm, Distance between centres: 1000 mm, Bed width: 186 mm, Motor: 2hp / 240v / 415v, Spindle bore: 38mm, Spindle Mount: MT5, Spindle speeds: 70-2000 rpm, Imperial Threads: 3 1/2 80-tpi / 38 step, Metric threads: 0.45-10mm / 23 step, Tailstock taper: MT3, Net weight: 430/475/524 kgs, DRO: 2 axis



# NEW Chester Commander 600 x 1000

## 2025607206N - Centre Lathe

Distance between Centres: 1000mm, Centre height: 300mm, Maximum Swing: 600mm, Swing over Cross Slide: 375mm, Swing in Gap: 800mm, Length in Gap: 280mm, Bed width: 400mm, Spindle Bore: 103mm, Spindle Taper: MT6, Spindle Nose - Camlock: D1-11, Tailstock Quill Diameter: 90mm, Tailstock Taper: MT6, Cross Slide Travel: 325mm, Compound Slide Travel: 110mm, Number of Speeds: 18 fwd / 6 rev, Range of Speeds (RPM): 9-1275 fwd / 16-816 rev, Motor: 11kw / 14.74hp, Power Supply: 415v, Net Weight: 2900kg

£15,200

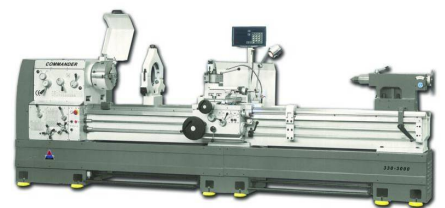

# NEW Chester Commander 600 x 1500

## 2025607207N - Centre Lathe

Distance between Centres: 1500mm, Centre height: 300mm, Maximum Swing: 600mm, Swing over Cross Slide: 375mm, Swing in Gap: 800mm, Length in Gap: 280mm, Bed width: 400mm, Spindle Bore: 103mm, Spindle Taper: MT6, Spindle Nose - Camlock: D1-11, Tailstock Quill Diameter: 90mm, Tailstock Taper: MT6, Cross Slide Travel: 325mm, Compound Slide Travel: 110mm, Number of Speeds: 18 fwd / 6 rev, Range of Speeds: 9-1275 fwd / 16-816 rev, Motor: 11kw / 14.74hp, Power Supply: 415v, Net Weight: 3150kg

£16,200

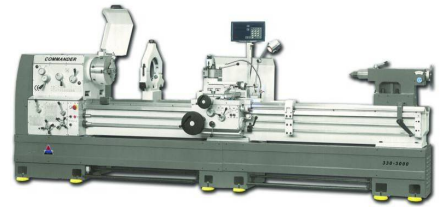

# NEW Chester Commander 600 x 2000

## 2025607208N - Centre Lathe

Distance between Centres: 2000mm, Centre height: 300mm, Maximum Swing: 600mm, Swing over Cross Slide: 375mm, Swing in Gap: 800mm, Length in Gap: 280mm, Bed width: 400mm, Spindle Bore: 103mm, Spindle Taper: MT6, Spindle Nose - Camlock: D1-11, Tailstock Quill Diameter: 90mm, Tailstock Taper: MT6, Cross Slide Travel: 325mm, Compound Slide Travel: 110mm, Number of Speeds: 18 fwd / 6 rev, Range of Speeds: 9-1275 fwd / 16-816 rev, Motor: 11kw / 14.74hp, Power Supply: 415v, Net Weight: 3400kg

£17,500



# NEW Chester Commander 600 x 3000

## 2025607209N - Centre Lathe

Distance between Centres: 3000mm, Centre height: 300mm, Maximum Swing: 600mm, Swing over Cross Slide: 375mm, Swing in Gap: 800mm, Length in Gap: 280mm, Bed width: 400mm, Spindle Bore: 103mm, Spindle Taper: MT7, Spindle Nose - Camlock: D1-11, Tailstock Quill Diameter: 90mm, Tailstock Taper: MT6, Cross Slide Travel: 325mm, Compound Slide Travel: 110mm, Number of Speeds: 18 fwd / 6 rev, Range of Speeds: 10-1275 fwd / 17-816 rev, Motor: 11kw / 14.74hp, Power Supply: 415v, Net Weight: 3800kg

£19,800

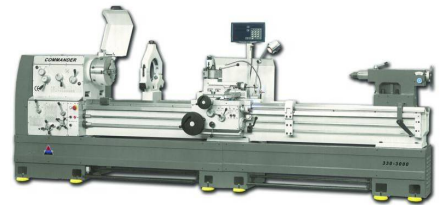

# NEW Chester Commander 660 x 1500

## 2025607210N - Centre Lathe

Distance between Centres: 1500mm, Centre height: 330mm, Maximum Swing: 660mm, Swing over Cross Slide: 435mm, Swing in Gap: 860mm, Length in Gap: 280mm, Bed width: 400mm, Spindle Bore: 103mm, Spindle Taper: MT6, Spindle Nose - Camlock: D1-11, Tailstock Quill Diameter: 90mm, Tailstock Taper: MT6, Cross Slide Travel: 325mm, Compound Slide Travel: 110mm, Number of Speeds: Fwd, 18 / Rev 6, Range of Speeds: fwd, 9-1275 / rev 16-816 rpm, Motor: 11kw, Power Supply: 415v, Net Weight: 3250kg

£16,600

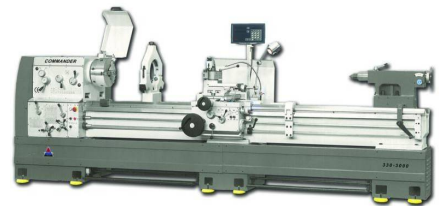

## NEW Chester Commander 660 x 2000

### 2025607211N - Centre Lathe

Distance between Centres: 2000mm, Centre height: 330mm, Maximum Swing: 660mm, Swing over Cross Slide: 435mm, Swing in Gap: 860mm, Length in Gap: 280mm, Bed width: 400mm, Spindle Bore: 103mm, Spindle Taper: MT6, Spindle Nose - Camlock: D1-11, Tailstock Quill Diameter: 90mm, Tailstock Taper: MT6, Cross Slide Travel: 325mm, Compound Slide Travel: 110mm, Number of Speeds: fwd, 18 / rev, 6, Range of Speeds: fwd, 9-1275 / rev, 16-816 rpm, Motor: 11kw, Power Supply: 415v, Net Weight: 3500kg

£17,500

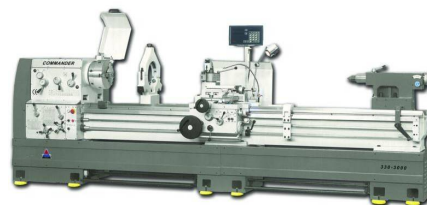

## NEW Chester Commander 800 x 2000

### 2025607212N - Centre Lathe

Distance between Centres: 2000mm, Centre height: 400mm, Maximum Swing: 800mm, Swing over Cross Slide: 545mm, Swing in Gap: 1000mm, Length in Gap: 280mm, Bed width: 400mm, Spindle Bore: 103mm, Spindle Taper: MT6, Spindle Nose - Camlock: D1-11, Tailstock Quill Diameter: 90mm, Tailstock Taper: MT6, Cross Slide Travel: 325mm, Compound Slide Travel: 110mm, Number of Speeds: fwd 18 / rev 6, Range of Speeds: fwd 9-1275 / rev 16-816 rpm, Motor: 11kw, Power Supply: 415v, Net Weight: 3650kg

£19,100

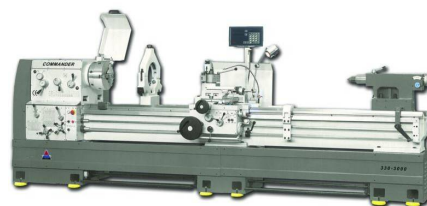

## NEW Chester Commander 660 x 3000

### 2025607213N - Centre Lathe

Distance between Centres: 3000mm, Centre height: 330mm, Maximum Swing: 660mm, Swing over Cross Slide: 435mm, Swing in Gap: 860mm, Length in Gap: 280mm, Bed width: 400mm, Spindle Bore: 103mm, Spindle Taper: MT6, Spindle Nose - Camlock: D1-11, Tailstock Quill Diameter: 90mm, Tailstock Taper: MT6, Cross Slide Travel: 325mm, Compound Slide Travel: 110mm, Number of Speeds: fwd 18 / rev 6, Range of Speeds: fwd 9-1275 / rev 16-816 rpm, Motor: 11kw, Power Supply: 415v, Net Weight: 3900kg

£20,200

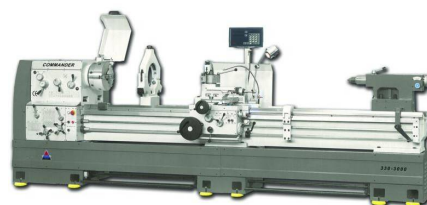

## NEW Chester Commander 800 x 3000

### 2025607214N - Centre Lathe

Distance between Centres: 3000mm, Centre height: 400mm, Maximum Swing: 800mm, Swing over Cross Slide: 545mm, Swing in Gap: 1000mm, Length in Gap: 280mm, Bed width: 400mm, Spindle Bore: 103mm, Spindle Taper: MT6, Spindle Nose - Camlock: D1-11, Tailstock quill diameter: 90mm, Tailstock Taper: MT6, Cross Slide Travel: 325mm, Compound Slide Travel: 110mm, Number of Speeds: fwd 18 / rev 6, Range of Speeds: fwd 9-1275 / rev 16-816 rpm, Motor: 11kw, Power Supply: 415v, Net Weight: 4050kg

£22,100

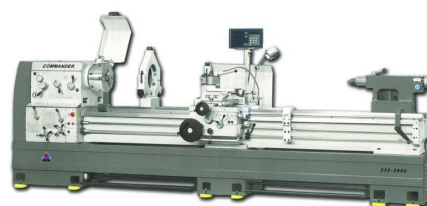

# NEW Chester Bristol VS

## 2025607216N - Centre Lathe

Distance between Centres: 1000mm, Centre height: 205mm, Maximum Swing: 410mm, Swing over Cross Slide: 255mm, Swing in Gap: 580mm, Length in Gap: 190mm, Bed width: 250mm, Spindle Bore: 52mm, Spindle Taper: MT6, Spindle Nose - Camlock: D1-6, Tailstock Quill Diameter: 50mm, Tailstock Taper: MT4, Cross Slide Travel: 210mm, Compound Slide Travel: 140mm, Max Tool Size: 20 x 20mm, Number of Speeds: Varispeed (H & L), Range of Speeds: 30-3000 rpm, Leadscrew Pitch: 0.05 - 1.7mm/rev, Cross Screw Pitch: 0.025 - 0.85mm/rev, Motor: 3.3kw, Power Supply: 415v, Net Weight: 1340kg

£8,100



# NEW Chester Bristol VS CSS

## 2025607217N - Centre Lathe

Distance between Centres: 1000mm, Centre height: 205mm, Maximum Swing: 410mm, Swing over Cross Slide: 255mm, Swing in Gap: 580mm, Length in Gap: 190mm, Bed width: 250mm, Spindle Bore: 52mm, Spindle Taper: MT6, Spindle Nose - Camlock: D1-6, Tailstock Quill Diameter: 50mm, Tailstock Taper: MT4, Cross Slide Travel: 210mm, Compound Slide Travel: 140mm, Max Tool Size: 20 x 20mm, Number of Speeds: Varispeed (H&L), Range of Speeds: 30-3000rpm, Leadscrew Pitch: 0.05 - 1.7mm/rev, Cross Screw Pitch: 0.025 - 0.85 mm/rev, Motor: 3.3kw, Power Supply: 415v, Net Weight: 1340kg

£9,460



# NEW Chester Valiant 500B x 1500

## 2025607218N - Centre Lathe with Digital Readout

Centre Height: 250mm, Distance between Centres: 1500mm, Max Swing: 500mm, Swing in Gap: 720mm, Bore: 140mm, Spindle Nose: D1-11, Speeds: 14 - 1250 rpm, Motor: 7.5kw / 10hp, Weight: 2300kg

£14,400



# NEW Chester Valiant 500B x 2000

## 2025607219N - Centre Lathe with Digital Readout

Centre Height: 250mm, Distance between Centres: 2000mm, Max Swing: 500mm, Swing in Gap: 720mm, Bore: 104mm, Spindle Nose: D1-11, Speeds: 14 - 1250 rpm, Motor: 7.5kw / 10hp, Weight: 2650kg

£16,400



# NEW Chester Challenger

## 2025607223N - Centre Lathe with Digital Readout

Turning Diameter Over Bed (mm): 356mm, Turning Diameter Over Slide (mm): 200mm, Center Distance (mm): 175mm, Spindle Bore (mm): 38mm, Main Drive Power (KW/V/Hz): 415V, Turning Length (mm): 1000mm, Spindle Turning Speed Range: 45 to 1800rpm, Feeds - Longitudinal: 0.043 - 0.653mm/rev, Feeds - Cross: 0.015 - 0.220mm/rev, Max. Swing-Dia. In Gap (mm): 506mm, Number Of Controlled Axis: 2 Axis DRO, Tailstock Spindle Travel: 125mm, Headstock Spindle Taper: MT5, Tailstock Spindle Taper: MT3, Motor: 3hp

£6,400



# NEW Chester Challenger Vari Speed

## 2025607224N - Centre Lathe with Digital Readout

Turning Diameter Over Bed (mm): 360mm, Turning Diameter Over Slide (mm): 220mm, Center Distance (mm): 180mm, Spindle Bore (mm): 38mm, Main Drive Power (KW/V/Hz): 415V, Turning Length (mm): 1000, Spindle Turning Speed Range: 45-1800 / 155-3000 rpm, Feeds - Longitudinal: 0.043 - 0.653mm/rev, Feeds - Cross: 0.015 - 0.220mm/rev, Max. Swing-Dia. In Gap (mm): 506mm, Number Of Controlled Axis: 2 Axis DRO, Tailstock Spindle Travel: 120mm, Headstock Spindle Taper: MT5 / D1-4, Tailstock Spindle Taper: MT3, Motor: 5.3hp

£5,800



# NEW Chester Sheffield

## 2025607225N - Centre Lathe

Turning Diameter Over Bed (mm): 400, Turning Diameter Over Slide (mm): 240, Center Distance (mm): 1000, Spindle Bore (mm): 52, Main Drive Power (KW/V/Hz): 415V, Turning Length (mm): 900, Spindle Turning Speed Range: 33 - 1600 rpm, Feeds - Longitudinal: 0.039 - 1.1mm, Feeds - Cross: 0.018 - 0.55mm, Max. Swing-Dia. In Gap (mm): 580, Tailstock Spindle Travel: 650 mm, Headstock Spindle Taper: MT4 / D1-6, Tailstock Spindle Taper: MT4, Motor: 5.5kw / 7.37hp, DRO: Yes, 2 axis

£8,800



# NEW Chester Monarch 1640

## 2025607226N - Centre Lathe with Digital Readout

Distance between Centres: 1000mm, Centre height: 205mm, Maximum Swing: 410mm, Swing over Cross Slide: 220mm, Swing in Gap: 640mm, Length in Gap: 165mm, Bed width: 300mm, Spindle Bore: 58mm, Spindle Taper: MT6, Spindle Nose - Camlock: D1-6, Tailstock Quill Diameter: 60mm, Tailstock Taper: MT4, Cross Slide Travel: 285mm, Max Tool Size: 25 x 25mm, Number of Speeds: 12, Range of Speeds: 25 - 2000rpm, Leadscrew Pitch: 6mm / 4 tpi, Motor: 5.5kw / 7.35hp, Power Supply: 415v, Net Weight: 1670kg, Dimensions: 2200 x 1080 x 1340mm



£10,100

---

# NEW Chester Monarch 1660

## 2025607227N - Centre Lathe with Digital Readout

Distance between Centres: 1500mm, Centre height: 205mm, Maximum Swing: 410mm, Swing over Cross Slide: 220mm, Swing in Gap: 640mm, Length in Gap: 165mm, Bed width: 300mm, Spindle Bore: 58mm, Spindle Taper: MT6, Spindle Nose - Camlock: D1-6, Tailstock Quill Diameter: 60mm, Tailstock Taper: MT4, Cross Slide Travel: 285mm, Max Tool Size: 25 x 25mm, Number of Speeds: 12, Range of Speeds: 25 - 2000rpm, Leadscrew Pitch: 6mm / 4tpi, Motor: 5.5kw / 7.35hp, Power Supply: 415v, Net Weight: 1920kg, Dimensions: 2750 x 1080 x 1340mm



£10,800

---

# NEW Chester Monarch 2040

## 2025607228N - Centre Lathe with Digital Readout

Distance between Centres: 1000mm, Centre height: 255mm, Maximum Swing: 510mm, Swing over Cross Slide: 305mm, Swing in Gap: 735mm, Length in Gap: 170mm, Bed width: 350mm, Spindle Bore: 80mm, Spindle Taper: MT7, Spindle Nose - Camlock: D1-8, Tailstock Quill Diameter: 75mm, Tailstock Taper: MT5, Cross Slide Travel: 316mm, Max Tool Size: 25 x 25mm, Number of Speeds: 12, Range of Speeds: 25 - 1600rpm, Leadscrew Pitch: 6mm / 4tpi, Motor: 7.5kw / 10.05hp, Power Supply: 415v, Net Weight: 2035kg, Dimensions: 2390 x 1150 x 1430mm



£12,100

---

# NEW Chester Monarch 2060

## 2025607229N - Centre Lathe with Digital Readout

Distance between Centres: 1500mm, Centre height: 255mm, Maximum Swing: 510mm, Swing over Cross Slide: 305mm, Swing in Gap: 735mm, Length in Gap: 170mm, Bed width: 350mm, Spindle Bore: 80mm, Spindle Taper: MT7, Spindle Nose - Camlock: D1-8, Tailstock Quill Diameter: 75mm, Tailstock Taper: MT5, Cross Slide Travel: 316mm, Max Tool Size: 25 x 25mm, Number of Speeds: 12, Range of Speeds: 25 - 1600rpm, Leadscrew Pitch: 6mm / 4tpi, Motor: 7.5kw / 10.05hp, Power Supply: 415v, Net Weight: 2160kg, Dimensions: 2840 x 1150 x 1430mm



£12,900

---

# NEW Chester Monarch 2080

## 2025607230N - Centre Lathe with Digital Readout

Distance between Centres: 2000mm, Centre height: 255mm, Maximum Swing: 510mm, Swing over Cross Slide: 305mm, Swing in Gap: 735mm, Length in Gap: 170mm, Bed width: 350mm, Spindle Bore: 80mm, Spindle Taper: MT7, Spindle Nose - Camlock: D1-8, Tailstock Quill Diameter: 75mm, Tailstock Taper: MT5, Cross Slide Travel: 316mm, Max Tool Size: 25 x 25mm, Number of Speeds: 12, Range of Speeds: 25 - 1600rpm, Leadscrew Pitch: 6mm / 4tpi, Motor: 7.5kw / 10.05hp, Power Supply: 415v, Net Weight: 2435kg, Dimensions: 3340 x 1150 x 1430mm



£12,700

---

# NEW Chester Oxford 400

## 2025607945N - Centre Lathe

Swing over bed: 400mm, Swing over crossslide: 250mm, Swing in Gap: 520mm, Centre height: 200mm, Length of gap: 100mm, Distance between centres: 1015mm, Bed width: 218mm, Motor: 1.5kw / 2hp, Spindle bore: 52mm, Spindle Mount: D5, Spindle speeds: 65 - 1800rpm, Cross slide travel: 230mm, Max tool size: 20 x 20mm, Tailstock taper: MT4, Tailstock quill diameter: 52mm, Net weight: 650kg, Dimensions: 1830 x 770 x 1300mm, DRO: 2 axis

£8,000



# NEW Chester Chieftain 26120

## 2025905801N - Centre Lathe with Digital Readout

Feeds - Longitudinal: 0.028-6.43mm/rev, Spindle Turning Speed Range: 36 - 1600rpm, Turning Length (mm): 3000mm, Spindle Bore (mm): 105mm, Length Of Gap: 240mm, Main Drive Power (KW/V/Hz): 415v, Center Distance (mm): 330mm, Max. Swing-Dia. In Gap (mm): 870mm, Feeds - Cross: 0.012-2.73mm/rev, Turning Diameter Over Slide (mm): 420mm, DRO: 2 axis, Bed width: 405mm, Spindle Taper: 130mm 1:20, Tailstock quill diameter: 75mm, Tailstock taper: MT5, Motor: 7hp, Net weight: 3350kgs, Dimensions: 4500x1100x1450mm

£31,000



# NEW Chester Halifax 630 x 1000

## 2025907201N - Centre Lathe

Centre Height: 310mm, Distance between Centres: 1000mm, Max Swing: 620mm, Swing in Gap: 800mm, Bore: 105mm (130mm available), Spindle Nose: D11, Speeds: 10-800rpm, Motor: 11kw, Power Supply: 415v / 3 phase, Weight: 4500kg, Dimensions: 3390 x 1400 x 2000mm

£26,600



# NEW Chester Halifax 830 x 1000

## 2025907202N - Centre Lathe

Centre Height: 415mm, Distance between Centres: 1000mm, Max Swing: 830mm, Swing in Gap: 1000mm, Bore: 105mm (130mm available), Spindle Nose: D11, Speeds: 10 - 800rpm, Motor: 11kw / 14.74hp, Power Supply: 415v / 3 phase, Weight: 4500kgs, Dimensions: 3390 x 1400 x 2000

£28,500



## NEW Chester Halifax 1030 x 1500

### 2025907203N - Centre Lathe

Centre Height: 515mm, Distance between Centres: 1500mm, Max Swing: 1030mm, Swing in Gap: 1200mm, Bore: 105mm (130mm available), Spindle Nose: D11, Speeds: 10 - 800rpm, Motor: 11kw / 14.74hp, Power Supply: 415v / 3 phase, Weight: 5900kgs, Dimensions: 3840 x 1700 x 1980mm

£34,800



## NEW Chester Halifax 1230 x 1500

### 2025907204N - Centre Lathe

Centre Height: 615mm, Distance between Centres: 1500mm, Max Swing: 1230mm, Swing in Gap: 1400mm, Bore: 105mm, (130mm available), Spindle Nose: D11, Speeds: 10 - 800rpm, Motor: 11kw / 14.74hp, Power Supply: 415v / 3 phase, Weight: 6400kgs, Dimensions: 3840 x 1700 x 2080mm

£36,500



## NEW Chester Halifax 1430 x 1500

### 2025907205N - Centre Lathe

Centre Height: 715mm, Distance between Centres: 1500mm, Max Swing: 1430mm, Swing in Gap: 1600mm, Bore: 105mm (130 available), Spindle Nose: D11, Speeds: 7 - 576 rpm, Motor: 11kw / 14.74hp, Power Supply: 415v / 3 phase, Weight: 7500kgs, Dimensions: 3840 x 1850 x 2220mm

£40,500



## NEW Chester Halifax 630 x 3000

### 2025907527N - Centre Lathe

Centre Height: 310mm, Distance between Centres: 3000mm, Max Swing: 620mm, Swing in Gap: 800mm, Bore: 105mm (130mm available), Spindle Nose: D11, Speeds: 10-800rpm, Motor: 11kw, Power Supply: 415v / 3 phase, Weight: 5000kg

£28,900

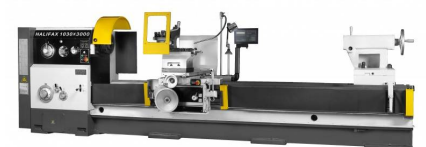

# NEW Chester OC

## 2035004428N - Oil Country Lathe

Turret/Tool Post: 4 way, Turning Speed Range: 25-400, Spindle Bore Diameter (mm): 360, Turning Length (mm): Options



# NEW Chester T Universal

## 2503005213N - Milling Machine - Turret / Horizontal

Motor Vertical: 2hp, Motor Horizontal: 1.5 hp, Table Size: 240 x 800mm, Range of Vertical Speeds: 50-3000rpm, Range of Horizontal Speeds: 20-2500rpm, Number of Spindle Speeds: Variable, Cross Travel: 280mm, Longitudinal Travel: 435mm, Vertical Travel: 860mm, Vertical Spindle Taper: ISO30, Horizontal Spindle Taper: ISO30, Maximum Distance Spindle to Table: 470mm, Max. Distance Vert. Spindle to Table: 180mm, Max Distance Horizontal Spindle to Table: 370mm, Quill Travel: 130mm, Horizontal Rotation of Ram: 360 Degrees, Head Rotation ( Left to Right): 90 Degrees, T Slot Size: 14mm, Dimensions: 2200 x 1250 x 1450mm, Weight: 850 Kgs

£4,390



# NEW Powercentre KM100

## 2510204404N - CNC Bed Milling Machine,

Table Dimensions (mm): 1370 X 400, X-Travel (mm): 1000, Y-Travel (mm): 500, Z-Travel (mm): 530, Control: C-Tek PC based Conversational, Number Of Tools In Magazine: n/a, Spindle Speed Range: 60-8,000 rpm, Distance Between Spindle & Table (Vertic): 680mm, Spindle Taper: BT40, Coolant Through Spindle: no, Rapid Traverse Range X,Y,Z: 8000mm/min, Additional Axes: Optional, Main Drive Power (KW/V/Hz): 10HP, Optional Control System: Siemens 828D

£28,500



## NEW Powercentre KM150

### 2510304405N - CNC Bed Milling Machine

Table Dimensions (mm): 1800 X 450, X-Travel (mm): 1500, Y-Travel (mm): 650, Z-Travel (mm): 620, Control: C-Tek PC based Conversational, Number Of Tools In Magazine: n/a, Spindle Speed Range: 60-6,000 rpm, Distance Between Spindle & Table (Vertic: 730mm, Spindle Taper: BT40, Coolant Through Spindle: no, Rapid Traverse Range X,Y,Z: 8000mm/min, Additional Axes: Optional, Main Drive Power (KW/V/Hz): 15HP, Optional Control System: Siemens 828D

£38,750



## NEW Powercentre KM180

### 2510304406N - CNC Bed Milling Machine

Table Dimensions (mm): 2100 X 450, X-Travel (mm): 1800, Y-Travel (mm): 650, Z-Travel (mm): 620, Control: C-Tek PC based Conversational, Number Of Tools In Magazine: n/a, Spindle Speed Range: 60-6,000 rpm, Distance Between Spindle & Table (Vertic: 730mm, Spindle Taper: BT40, Coolant Through Spindle: no, Rapid Traverse Range X,Y,Z: 8000mm/min, Main Drive Power (KW/V/Hz): 15HP

£41,985



## NEW Femco BMC110T2

### 2510304449N - CNC Horizontal Column Moving Boring & Milling Machine

Horizon/Vertical/Universal: Horizontal, Control + No Of Axis: Fanuc OiM (21iM option), Table Size: 1440 x 1600, Spindle Taper: ISO 50, Spindle Speeds: 2500rpm, Feeds: 12 m/m



## NEW Powercentre KM180

### 2510304420N - Milling - Vertical Machining Centre

Table Dimensions (mm): 2100 X 450, X-Travel (mm): 1800, Y-Travel (mm): 650, Z-Travel (mm): 620, Control: C-Tek PC based Conversational, Number Of Tools In Magazine: 24, Spindle Speed Range: 60-6,000 rpm, Distance Between Spindle & Table (Vertic: 730mm, Spindle Taper: BT40, Rapid Traverse Range X,Y,Z: 8000mm/min, Additional Axes: optional, Main Drive Power (KW/V/Hz): 15HP

£48,750



## NEW Powercentre KM80

### 2515204762N - Vertical Machining Centre with 4th Axis

Table Dimensions (mm): 1270 X 305, X-Travel (mm): 800, Y-Travel (mm): 500, Z-Travel (mm): 500, Control: C-Tek PC based Conversational, Number Of Tools In Magazine: 16, Spindle Speed Range: 60-8,000 rpm, Distance Between Spindle & Table (Vertic: 620mm, Spindle Taper: BT40, Coolant Through Spindle: no, Rapid Traverse Range X,Y,Z: 10000mm/min, Additional Axes: Yes, Main Drive Power (KW/V/Hz): 7.5HP

£39,995

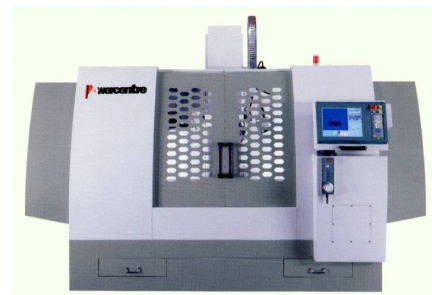

## NEW Powercentre KM80

### 2515205662N - Vertical Machining Centre

Table Dimensions (mm): 1270 X 305, X-Travel (mm): 800, Y-Travel (mm): 500, Z-Travel (mm): 500, Control: C-Tek PC based Conversational, Number Of Tools In Magazine: 16, Spindle Speed Range: 60-8,000 rpm, Distance Between Spindle & Table (Vertic: 620mm, Spindle Taper: BT40, Rapid Traverse Range X,Y,Z: 12000mm/min, Main Drive Power (KW/V/Hz): 7.5HP, 4th / 5th Axis: Optional Extra, Opinion: The best value VMC on Market.

£31,950

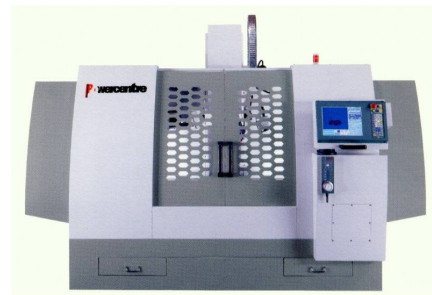

## NEW Powercentre KM80

### 2515206523N - Milling Machine - CNC Bed Type

Table Dimensions (mm): 1270 X 305, X-Travel (mm): 800, Y-Travel (mm): 500, Z-Travel (mm): 500, Control: C-Tek PC based Conversational, Spindle Speed Range: 60-8,000 rpm, Distance Between Spindle & Table (Vertic: 620mm, Spindle Taper: BT40, Rapid Traverse Range X,Y,Z: 12000mm/min, Main Drive Power (KW/V/Hz): 7.5HP, 4th / 5th Axis: Optional Extra, Opinion: The best value on Market.

£25,850



## NEW Powercentre KM1000L

### 2515206823N - Vertical Machining Centre

Table Dimensions (mm): 1200 X 500, X-Travel (mm): 800, Y-Travel (mm): 1050, Z-Travel (mm): 600, Control: C-Tek PC based Conversational, Number Of Tools In Magazine: 16, Spindle Speed Range: 60-8,000 rpm, Distance Between Spindle & Table (Vertic: 620mm, Spindle Taper: BT40, Rapid Traverse Range X,Y,Z: 20,000mm/min, Main Drive Power (KW/V/Hz): 15HP, 4th / 5th Axis: Optional Extra, Opinion: The best value VMC on Market., 10,000 rpm: Optional Extra, Linear Guides: Yes

£43,000

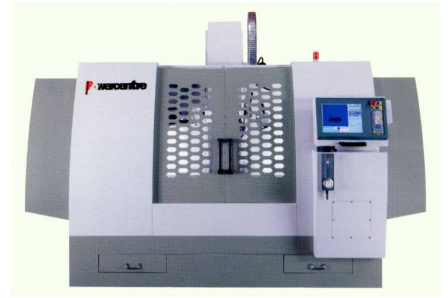

## NEW Powercentre KM80L

### 2515207027N - Milling Machine - CNC Bed Type

Table Dimensions (mm): 1270 X 305, X-Travel (mm): 800, Y-Travel (mm): 600, Z-Travel (mm): 500, Control: C-Tek PC based Conversational, Spindle Speed Range: 60-8,000 rpm, Distance Between Spindle & Table (Vertic: 620mm, Spindle Taper: BT40, Rapid Traverse Range X,Y,Z: 20,000mm/min, Main Drive Power (KW/V/Hz): 7.5HP, 4th / 5th Axis: Optional Extra, Opinion: The best value on Market., Linear Guideways: Yes

£29,950

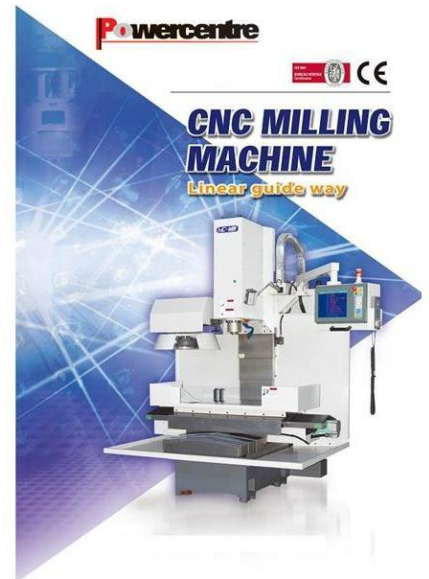

## NEW Powercentre KM100L

### 2515207028N - Milling Machine - CNC Bed Type

Table Dimensions (mm): 1270 X 305, X-Travel (mm): 1000, Y-Travel (mm): 600, Z-Travel (mm): 500, Control: C-Tek PC based Conversational, Spindle Speed Range: 60-8,000 rpm, Distance Between Spindle & Table (Vertic: 620mm, Spindle Taper: BT40, Rapid Traverse Range X,Y,Z: 20,000mm/min, Main Drive Power (KW/V/Hz): 7.5HP, 4th / 5th Axis: Optional Extra, Opinion: The best value on Market., Linear Guideways: Yes

£29,995

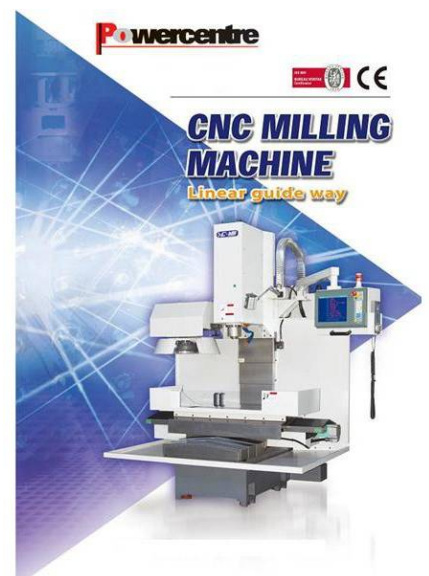

## NEW Powercentre KM80L

### 2515207478N - Milling Machine - Vertical Machining Centre

Table Dimensions (mm): 1270 X 305, X-Travel (mm): 800, Y-Travel (mm): 600, Z-Travel (mm): 500, Control: C-Tek PC based Conversational, Spindle Speed Range: 60-8,000 rpm, Distance Between Spindle & Table (Vertic: 620mm, Spindle Taper: BT40, Rapid Traverse Range X,Y,Z: 20,000mm/min, Main Drive Power (KW/V/Hz): 7.5HP, 4th / 5th Axis: Optional Extra, Opinion: The best value on Market., Linear Guideways: Yes

£34,995

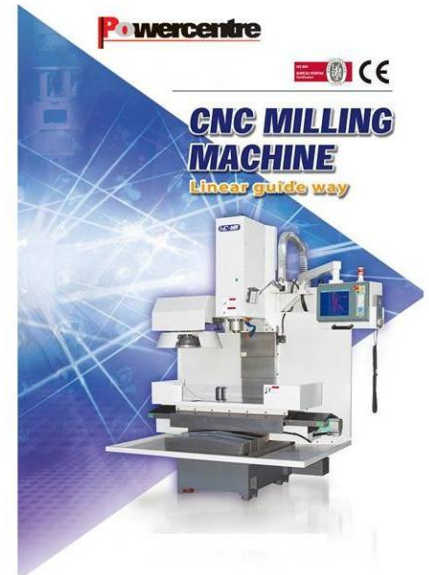

## NEW Powercentre KM100

### 2515306301N - Milling Machine - CNC Vertical

Table Dimensions (mm): 1370 X 400, X-Travel (mm): 1000, Y-Travel (mm): 500, Z-Travel (mm): 530, Control: C-Tek PC based Conversational, Number Of Tools In Magazine: 16, Spindle Speed Range: 60-8,000 rpm, Distance Between Spindle & Table (Vertic: 680mm, Spindle Taper: BT40, Thread Capacity: 12mm, Feed Power: 1 kw, Rapid Traverse Range X,Y,Z: 8000mm/min, Main Drive Power (KW/V/Hz): 10HP

£34,850



## NEW Powercentre KM150

### 2515604419N - Milling - Vertical Machining Centre

Table Dimensions (mm): 1800 X 450, X-Travel (mm): 1500, Y-Travel (mm): 650, Z-Travel (mm): 620, Control: C-Tek PC based Conversational, Number Of Tools In Magazine: 16, Spindle Speed Range: 60-8,000 rpm, Distance Between Spindle & Table (Vertic: 730mm, Spindle Taper: BT40, Rapid Traverse Range X,Y,Z: 8000mm/min, Additional Axes: Optional, Main Drive Power (KW/V/Hz): 15HP

£45,000



## NEW Powercentre KM2085

### 2515805031N - CNC Vertical Machining Centre

Table Dimensions (mm): 2200 X 810, X-Travel (mm): 2000, Y-Travel (mm): 850, Z-Travel (mm): 710, Control: C-Tek PC based Conversational, Number Of Tools In Magazine: 21, Spindle Speed Range: 60-6,000 rpm, Distance Between Spindle & Table (Vertic: 730mm, Spindle Taper: BT40, Rapid Traverse Range X,Y,Z: 15000mm/min, Additional Axes: optional, Main Drive Power (KW/V/Hz): 20HP, Spindle Chiller: Yes

£59,000



## NEW Powercentre KM2585

### 2515805032N - CNC Vertical Machining Centre

Table Dimensions (mm): 2500 X 810, X-Travel (mm): 2500, Y-Travel (mm): 850, Z-Travel (mm): 710, Control: C-Tek PC based Conversational, Number Of Tools In Magazine: 21, Spindle Speed Range: 60-6,000 rpm, Distance Between Spindle & Table (Vertic: 730mm, Spindle Taper: BT40, Rapid Traverse Range X,Y,Z: 15000mm/min, Additional Axes: optional, Main Drive Power (KW/V/Hz): 20HP, Spindle Chiller: Yes

£64,000

## NEW Powercentre KM2085

### 2515806525N - Milling Machine - CNC Bed Type

Table Dimensions (mm): 2200 X 810, X-Travel (mm): 2000, Y-Travel (mm): 850, Z-Travel (mm): 710, Control: C-Tek PC based Conversational, Spindle Speed Range: 60-6,000 rpm, Distance Between Spindle & Table (Vertic: 730mm, Spindle Taper: BT40, Rapid Traverse Range X,Y,Z: 15000mm/min, Additional Axes: optional, Main Drive Power (KW/V/Hz): 20HP

£53,500



## NEW Chester VB Series

### 2515904427N - Vertical Boring Machines - Manual & CNC

Table-Size: 900 to 1800mm, Further Details: On Request



# NEW Chester Superlux

## 2520604329N - Vertical Milling Machine

Horizontal / Vertical / Universal: Vertical, X/Y/Z Travel: 590 x 220, Table Size: 240 x 800, Spindle Taper: MT3, Spindle Speeds: 95-1600, Power Capacity: 240 volts 1phase

£2,780



---

# NEW Chester 836

## 2520605092N - Turret Mill

Horizontal / Vertical / Universal: Turret, Control + No Of Axis: 2 Axis DRO, X/Y/Z Travel: 660 x 200, Table Size: 230 x 1067, Spindle Taper: R8, Spindle Speeds: 200-1300, Feeds: Power Longitudinal - Variable, Power Capacity: 1.5 HP, Standard Eqpt: Vice, Clamping Kit, DRO, Coolant, Tray,, Electrics: 1 or 3 phase

£7,500



# NEW Astra 3VS Super

## 2520607234N - Turret Mill

Horizontal / Vertical / Universal: Turret, Control + No Of Axis: 3 Axis DRO, X/Y/Z Travel: 800 (auto) / 400 / 406mm, Table Size: 1370 x 254mm, Spindle Taper: R8, Spindle Speeds: 66 - 3165rpm, Feeds: Quill, Cross, Long, Power Capacity: 2.25kw / 3hp, Standard Eqpt: Vice, coolant, lamp, clamp kit, Standard Eqpt: collet set, drill chuck.

**£8,300**



# NEW Astra 5VS Super

## 2520607235N - Turret Mill

Horizontal / Vertical / Universal: Turret, Control + No Of Axis: 3 Axis DRO, X/Y/Z Travel: 800 (auto) / 400 / 406mm, Table Size: 1370 x 254mm, Spindle Taper: ISO40, Spindle Speeds: 66 - 3165rpm, Feeds: 3 axis, Power Capacity: 3.75kw / 5hp, Standard Eqpt: Air drawbar, Vice, coolant, lamp, , Standard Eqpt: clamp kit, drill chuck

**£18,000**



# NEW Chester 830VS-R

## 2520607298N - Turret Mill

Horizontal / Vertical / Universal: Turret, X/Y/Z Travel: 470 x 200 x 460mm, Table Size: 760 x 205mm, Spindle Taper: R8, Spindle Speeds: 200-2250 rpm, Feeds: Fine feed on Quill, Power Capacity: 1.5hp, Standard Eqpt: Stand, Collet chuck, Electronic brake, Electrics: 240 volt

£4,300



---

# NEW Chester 830VS

## 2520607299N - Turret Mill

Horizontal / Vertical / Universal: Turret, X/Y/Z Travel: 470 x 200 x 455mm, Table Size: 760 x 205mm, Spindle Taper: R8, Spindle Speeds: 200-2250 rpm, Feeds: Fine feed on Quill, Power Capacity: 1.5hp, Standard Eqpt: Stand, Collet Chuck, electronic brake, Electrics: 240 volt

£4,530



## NEW Astra 3VS

### 2520607954N - Turret Mill

Horizontal / Vertical / Universal: Turret, Control + No Of Axis: 3 Axis DRO, X/Y/Z Travel: 640 (auto) / 305 / 406mm, Table Size: 1067 x 230mm, Spindle Taper: R8, Spindle Speeds: 50 - 3500rpm, Feeds: Yes, Power Capacity: 2.25kw / 3hp, Standard Eqpt: Vice, coolant, light, clamp kit, , Standard Eqpt: collet set, drill chuck.

£10,000



## NEW Chester 1466 Super

### 2520907141N - Milling Machine - Turret / Horizontal

Horizontal / Vertical / Universal: Variable Speed Turret with Horizontal , Digital Readout: 3 Axis, X/Y/Z Travel: 1000 x 300 x 40, Table Size: 1650mm x 360mm, Spindle Taper: 40 Int Vertical and 50 Horiz, Spindle Speeds: 70 - 3620 Vert and 58 - 1800rpm Horiz, Feeds: In 3 Directions, Power Capacity: 7hp, Drilling Dia: 30mm Dia max, Quill Travel: 127mm, Vert Spindle Nose to Table: 200 - 600mm, Horizontal Spindle to Table: 0-380mm, Power feed in all Directions: Yes

£18,300



## NEW Astra G6-1

### 2525007236N - Milling Machine - Bed Type

Spindle Taper: BT50, Table Size: 1850 x 650mm, Longitudinal Travel: 1500mm, Horizon/Vertical/Universal: Vertical (Horizontal optional), DRO: Yes, 3 axis, Cross travel: 800mm, Y Slideway width: 1500mm, Slide Height: 800mm (max), Slideway width: 500mm, Spindle Motor: 5.5kw / 7.5hp, Spindle Speeds: 83 - 3000 rpm, Weight: 6200kg

£85,500



## NEW Astra Apollo

### 2525007238N - Milling Machine - Bed Type

Spindle Taper: Iso 50 Hor & Vert, Table Size: 2400 x 650 mm, X / Y / Z Travels: 1630 x 600 x 800mm, Horizon/Vertical/Universal: Horizontal & Vertical, DRO: Yes, 4 axis, Spindle Quill travel: 190mm Hor & Vert, Spindle Speeds Vertical: 23 - 1000 rpm, Spindle Speeds Horizontal: 23 - 1000 rpm, Weight : 17000 kg

£77,400



## NEW Astra Titan

### 2525007239N - Milling Machine - Bed Type

Spindle Taper: Iso 50, Table Size: 2500 x 600mm, X / Y / Z Travels: 1500 x 650 x 700mm, Horizon/Vertical/Universal: Horizontal & Vertical, DRO: Yes, 3 axis, Spindle Speeds : 50 - 1624 rpm, Power feeds: 3 axis

£53,800



## NEW Astra G6-2

### 2525007317N - Milling Machine - Bed Type

Spindle Taper: BT50, Table Size: 2600 x 650mm, Longitudinal Travel: 2400mm, Horizon/Vertical/Universal: Vertical (Horizontal optional), DRO: Yes, 3 axis, Cross travel: 800mm, Y Slideway width: 1500mm, Slide Height: 800mm (max), Slideway width: 500mm, Spindle Motor: 5.5kw / 7.5hp, Spindle Speeds: 83 - 3000 rpm, Weight: 8200kg

£97,900



## NEW Chester U40 Universal

### 2530604499N - Milling Machine - Universal with Vertical Head

Control + No Of Axis: optional, X/Y/Z Travel: 750mm x 252mm x 400mm, Table Size: 1320 x 320, Spindle Taper: 40 Int Vertical / 50 Int horizontal, Spindle Speeds: 58-1800, Feeds: Yes, 20-360m/m / 1200mm/min rapids, Motor: 4kw

£18,000



## NEW Chester Leicester 40

### 2530605220N - Toolroom Mill

Feed rates - vertical spindle: 00.03 - 0.12mm/rev, Spindle Speeds: 50 - 2500 rpm, Spindle Taper: ISO40, Spindle Speeds Vertical / Horizontal: 18, X/Y/Z Travel: 500mm x 350mm x 400mm, Table Size: 250 x 950, Motor: 3KW, DRO: No, Horizontal Arbor: Yes, Power Supply: 415volts/3 phase/50HZ

£22,400



## NEW Chester Model T

### 2530606156N - Milling Machine - Universal with Turret Head

X/Y/Z Travel: 730mm x 230mm x 360mm, Table Size: 240 x 1000, Spindle Taper: 30 Int Vertical / 30 Int horizontal, Spindle Speeds: 20-3000, Feeds: Power Long Travel, Motor: 2hp, Quill Travel: 130mm, DRO: 3 axis

£5,400



## NEW Chester Victory 260

### 2530606906N - Milling Machine - Universal Motorised Overarm

Spindle Speeds: 40-1600rpm, Spindle Taper: 40 INT, Table Size: 1120mm x 260mm, Power Supply: 415volts/3 phase/50hz, X/Y/Z Travel: 600mm x 280mm x 440mm, DRO: Yes, Motor: 2.2KW

£7,800

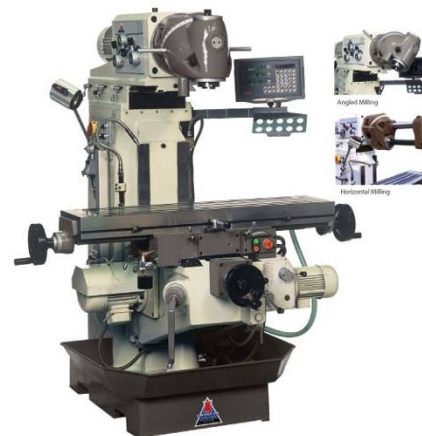

## NEW Chester Leicester 32

### 2530607237N - Toolroom Mill

Feed rates - vertical & horz spindle: 10 - 380 mm/min, Spindle Taper Vertical / Horizontal.: Iso 40, Spindle Speeds Vertical / Horizontal: 40 - 2000 rpm, X/Y/Z Travel: 400 x 300 x 390 mm, Table Size Horizontal: 750 x 320 mm, Table Size Vertical: 830 x 225 mm, DRO: Yes, 3 axis, Horizontal Arbor: Yes, Power Supply: 415volts/3 phase/50HZ, Vertical quill travel: 80mm

£18,700



## NEW Chester Victory 360

### 2530607249N - Milling Machine - Universal Motorised Overarm

Spindle Speeds: Vert 58 - 1800 / Horz 60 - 1750 rpm, Spindle Taper: Iso 50, Table Size: 1320 x 360mm, Power Supply: 415volts/3 phase/50hz, X/Y/Z Travel: 1000 / 300 / 400, DRO: 3 axis, Motor: 5.36hp, Swivel angle of table: +/- 35 degrees, Swivel angle of head: 360 degrees, Weight: 2300kg

£13,800



## NEW Chester Victory 360L

### 2530607250N - Milling Machine - Universal Motorised Overarm

Spindle Speeds: Vert 58 - 1800 / horz 60 - 1750, Spindle Taper: Iso 50, Table Size: 1600 x 360mm, Power Supply: 415volts/3 phase/50hz, X/Y/Z Travel: 1300 / 300 / 400, DRO: 3 axis, Motor: 5.36hp, Weight: 2400kg, Swivel angle of table : +/- 35 degrees, Swivel angle of head : 360 degrees

£16,400



## NEW Chester Victory 320

### 2530607251N - Milling Machine - Universal Motorised Overarm

Spindle Speeds: Vert 5 - 1660 / Horz 40 - 1300 rpm, Spindle Taper: Iso 40, Table Size: 1320 x 320mm, Power Supply: 415volts/3 phase/50hz, X/Y Travel: 1000mm / 300mm, DRO: Yes 3 axis, Motor: 3kw / 4hp, Distance between spindle & table: 0 - 440mm, Weight: 2100kg

£11,900



## NEW Chester U40S

### 2530607252N - Milling Machine - Universal with Vertical Head

Control + No Of Axis: 3 Axis DRO, X/Y/Z Travel: 1000 x 300 x 400mm, Table Size: 1320 x 360mm, Spindle Taper: Vert Iso 40 / Horz Iso 50, Spindle Speeds: 58 - 1800 rpm, Feeds: 22 - 420 mm/min, Motor: 4kw / 5.36hp, Weight : 2200kgs

£18,000



## NEW Chester Triumph Super

### 2530607334N - Milling Machine - Universal Motorised Overarm

Spindle Speeds: Vert 50 - 1500 / Horz 60 - 1800 rpm, Spindle Taper: Iso 50, Table Size: 2000 x 360mm, Power Supply: 415volts/3 phase/50hz, X/Y/Z Travel: 1600 / 400 / 500, DRO: 3 axis, Motor: 5.5kw, Swivel angle of table: +/- 35 degrees, Swivel angle of head: 360 degrees, Weight: 3890kg

£26,000



## NEW Chester Model T Super

### 2530607504N - Milling Machine - Universal with Turret Head

X/Y/Z Travel: 600mm x 260mm x 300mm, Table Size: 280 x 1200, Spindle Taper: MT4 Vertical / ISO40 horizontal, Spindle Speeds Vert / Horz: 115-1750 / 40-130 rpm, Feeds: Power Long Travel, Motor: 2hp, Quill Travel: 120mm, DRO: 3 axis, Weight : 1250 kgs

£7,200



## NEW Chester 626 Turret c/w DRO & Pwr feed

### 2535305806N - Milling Machine - Turret

Spindle Speeds: 300 - 5000rpm, Spindle Taper: MT3, Table Size: 660 x 152mm, X/Y/Z Travel: 440 x 290 x 240mm, Power supply: 240 volt, Drilling Capacity: 32mm, End Milling Capacity: 25mm, Face Milling Capacity: 75mm, Min Distance spindle to table: 10mm, Max Distance between spindle and column: 400mm, Head Tilt: 45 degrees left or right, Knee travel: 460mm, Motor: 2 hp, Dimensions: 1499x1500x1800mm, Weight: 500kgs, DRO: Yes

£2,480



## NEW Chester 626 Basic with DRO

### 2535307296N - Turret milling machine with DRO

Spindle Speeds: 300 - 5000rpm, Spindle Taper: MT3, Table Size: 660 x 250mm, X/Y/Z Travel: 440 x 290 x 240mm, Power supply: 240 volt, Drilling Capacity: 32mm, End Milling Capacity: 25mm, Face Milling Capacity: 75mm, Min Distance spindle to table: 10mm, Max Distance between spindle and column: 400mm, Head Tilt: 45 degrees left or right, Knee travel: 460mm, Motor: 2 hp, Dimensions: 1499x1500x1800mm, Weight: 500kgs, DRO: No

£2,300



## NEW Chester H110

### 3005304862N - Bandsaw - Horizontal

Cutting Speed (M/S): 20, 30 & 50 m/min, Dimensions Of Saw-Band (mm): 965 x 410 x 500mm, Cutting Width (mm): 100 x 150, Saw Band Length (mm): 1640 x 0.65 x 13mm, Main Drive Power (KW/V/Hz): 550w, Cutting Diameter (mm): 110, Horizontal / Vertical / Manual / Semi Au: Horizontal, Electrics: 240v

£265



## NEW Chester H80

### 3005304863N - Bandsaw - Horizontal

Cutting Speed (M/S): 20, 29 750m/min, Dimensions Of Saw-Band (mm): 760 x 295 x 465, Cutting Width (mm): 70 x 65, Saw Band Length (mm): 1300 x 0.63 x 12.5, Main Drive Power (KW/V/Hz): 420w, Cutting Diameter (mm): 90, Horizontal / Vertical / Manual / Semi Au: Horizontal, Electrics: 240v

£211



## NEW Chester HV128

### 3005304871N - Bandsaw - Horizontal

Cutting Speed (M/S): 65, 95, 165 fpm, Dimensions Of Saw-Band (mm): 64.5" x 1/2", Cutting Width (mm): 4" x 6", Saw Band Length (mm): 64" x 52", Main Drive Power (KW/V/Hz): 1/3hp, Cutting Diameter (mm): 5", Horizontal / Vertical / Manual / Semi Au: Horizontal, Electrics: 240v

£370



## NEW Chester 812

### 3005305071N - Bandsaw - Horizontal

Horizontal / Vertical / Manual / Semi Au: Horizontal, Cutting Diameter (mm): 200, Saw Band Length (mm): 93", Cutting Width (mm): 12", Dimensions Of Saw-Band (mm): 3/4", Cutting Speed (M/S): 81-270 feet per min, Control: Hydraulic Downfeed, Main Drive Power (KW/V/Hz): 3/4hp, Electrics: 1 or 3 phase, Cutting Cap Rectangles: 175mm x 300mm

£1,288



## NEW Chester HV128S

### 3005307505N - Bandsaw - Horizontal

Cutting Speed (M/S): 65, 95, 165 fpm, Dimensions Of Saw-Band (mm): 1635 x 12.7 x 0.65mm, Cutting Width (mm): 150 x 128mm, Main Drive Power (KW/V/Hz): 1/3hp, Cutting Diameter (mm): 128mm, Horizontal / Vertical / Manual / Semi Au: Horizontal, Electrics: 240v, Weight : 78 kgs

£580



## NEW Chester 712

### 3005307506N - Bandsaw - Horizontal

Horizontal / Vertical / Manual / Semi Au: Horizontal, Cutting Diameter (mm): 178, Saw Band Length (mm): 2362mm, Cutting Width (mm): 305, Dimensions Of Saw-Band (mm): 2362 x 19.05 x 0.8, Cutting Speed (M/S): 22 - 64 m/min, Control: Hydraulic Downfeed, Main Drive Power (KW/V/Hz): 3/4hp, Electrics: 240v single phase, Cutting Cap Rectangles: 178mm x 305mm, Weight : 170 kgs

£932



## NEW Bianco 280M

### 3005603929N - Horizontal Pull Down Bandsaw

Horizontal / Vertical / Manual / Semi Au: Horizontal, Cutting Diameter (mm): 220, Saw Band Length (mm): 2450, Cutting Width (mm): 105, Dimensions Of Saw-Band (mm): 1200 x 730 x 1500, Cutting Speed (M/S): Manual, Control: Manual, Main Drive Power (KW/V/Hz): 0.5/1.1



## NEW Chester H330SA

### 3005604620N - Horizontal Bandsaw - Semi Automatic

Horizontal / Vertical / Manual / Semi Au: Semi Auto, Cutting Diameter (mm): 330mm, Drive Motor: 1.5kw/3ph/415v, Coolant Motor: 7w/0.09kw, Blade Speed Range: 15-90m/min - 50-300ft/min., Blade Size: 3760 x 27 x 0.9mm, Bed Height: 707mm, Total Height: 1177mm, Width: 840mm, Length: 1751mm, Net weight: 355 kilos, Limited Offer: Price is 'Available whilst stock last'

£5,295



## NEW Chester 1018T

### 3005605131N - Horizontal Bandsaw - Swivel Base

Horizontal / Vertical / Manual / Semi Au: Horizontal with Swivel base, Cutting Diameter (mm): 250, Saw Band Length (mm): 1", Cutting Width (mm): 131/2", Cutting Speed (M/S): 50-275 ft / min, Main Drive Power (KW/V/Hz): 2HP, Blade Size: 1" x 144"

£4,710



## NEW Chester 1018V

### 3005605498N - Horizontal Bandsaw

Horizontal / Vertical / Manual / Semi Au: Horizontal, Cutting Diameter (mm): 10" Dia / 9" Sq / 8" x 16" Rect, Saw Band Length (mm): 1", Cutting Width (mm): 16", Dimensions Of Saw-Band (mm): 132 1/2", Cutting Speed (M/S): 50-275 ft / min variable speed, Main Drive Power (KW/V/Hz): 2hp

£3,700



## NEW Chester 916

### 3005606058N - Bandsaw - Horizontal

Horizontal / Vertical / Manual / Semi Au: Horizontal, Max Cutting Diameter 90 degrees(mm): 230mm, Max Cutting Diameter 45 degrees(mm): 180mm, Cutting rectangle 90 degrees(mm): 150mm x 400mm, Dimensions Of Saw-Band (mm): 3265mm x 27mm, Cutting Speed (M/m): 15, 38, 61 & 84 M per min, Main Drive Power (KW/V/Hz): 1.5Kw 415v 50 Hz

£3,815



## NEW Chester H300DC

### 3005607046N - Horizontal Bandsaw - Semi Automatic

Horizontal / Vertical / Manual / Semi Au: Semi Auto, Cutting Diameter (mm): 300mm, Drive Motor: 3HP/3ph/415v, Blade Speed Range: 22-84m/min, Blade Size: 34 x 1.1 x 3950, Total Height: 2100, Width: 1100, Length: 1400, Net weight: 680 kilos, Double Column: Yes

£7,000



## NEW Chester G350

### 3005607709N - Double Mitre Bandsaw

Horizontal / Vertical / Manual / Semi Au: Horizontal, Cutting Diameter (mm): 270, Cutting Width (mm): 350 x 240, Cutting Speed : 36 / 72 mm/min, Control: Manual, Main Drive Power (KW/V/Hz): 415v / 2.5hp, Down Feed: Yes, Coolant System: yes, Vice: Yes

£4,600



## NEW Chester G280

### 3005607710N - Double Mitre Bandsaw

Horizontal / Vertical / Manual / Semi Au: Horizontal, Cutting Diameter (mm): 225, Cutting Width (mm): 245 x 150, Cutting Speed : 45 / 90 mm/min, Control: Manual, Main Drive Power (KW/V/Hz): 415v / 1.5hp, Down Feed: Yes, Coolant System: yes, Vice: Yes

£2,450



## NEW Chester G300

### 3005607711N - Double Mitre Bandsaw

Horizontal / Vertical / Manual / Semi Au: Horizontal, Cutting Diameter (mm): 225, Cutting Width (mm): 310 x 210, Cutting Speed : 45 / 90 mm/min, Control: Manual, Main Drive Power (KW/V/Hz): 415v / 2 hp, Down Feed: Yes, Coolant System: yes, Vice: Yes, Cutting Capacity Square (mm): 210 x 210

£2,820



## NEW Chester G300R

### 3005607712N - Double Mitre Bandsaw

Horizontal / Vertical / Manual / Semi Au: Horizontal, Cutting Diameter (mm): 225, Cutting Width (mm): 315 x 230, Cutting Speed : 45 / 90 mm/min, Control: Manual, Main Drive Power (KW/V/Hz): 415v / 2 hp, Coolant System: yes, Vice: Yes, Cutting Capacity Square (mm): 230 x 230, Round Table: Yes, Mitres: 45 deg LH / 60 deg RH

£3,550



## NEW Chester G275

### 3005607724N - Single Mitre Bandsaw

Horizontal / Vertical / Manual / Semi Au: Horizontal, Cutting Diameter (mm): 225, Cutting Speed : 45 / 90 mm/min, Control: Manual, Main Drive Power (KW/V/Hz): 415v / 1.5 hp, Coolant System: yes, Vice: Yes, Cutting Capacity Square (mm): 245 x 180, Mitre : 0 - 45 degrees

£1,620



## NEW Chester G210

### 3005607725N - Single Mitre Bandsaw

Horizontal / Vertical / Manual / Semi Au: Horizontal, Cutting Diameter (mm): 170, Cutting Speed : 45 / 80 mm/min, Control: Manual, Main Drive Power (KW/V/Hz): 415v / 1hp, Coolant System: yes, Vice: Yes, Cutting Capacity Square (mm): 140 x 140, Mitre : 0 - 45 degrees

£1,370



## NEW Chester KP200

### 3010304437N - Hacksaw - Hydraulic

Manual/Automatic: Manual, Cutting Diameter (mm): 200mm, Dimensions Of Saw-Blade (mm): 350 x 32 x 16tpi, Stroke (mm): 120mm, Capacity 90 Degrees: Square: 190 x 200, Capacity 45 Degrees: Round: 90, Capacity 45 Degrees: Square: 190 x 90, Main Drive Power (KW/V/Hz): 1 hp

£3,800



## NEW Chester KP225

### 3010307258N - Hacksaw - Hydraulic

Manual/Automatic: Manual, Cutting Diameter (mm): 225mm, Dimensions Of Saw-Blade (mm): 400 x 32 x 1.6mm, Stroke (mm): 140mm, Capacity 90 Degrees: Square: 240 x 210mm, Capacity 45 Degrees: Round: 120mm, Capacity 45 Degrees: Square: 210 x 120, Main Drive Power (KW/V/Hz): 2hp / 415v

£4,500



## NEW Chester KP280

### 3010307259N - Hacksaw - Hydraulic

Manual/Automatic: Manual, Cutting Diameter (mm): 280mm, Dimensions Of Saw-Blade (mm): 450 x 32 x 1.6mm, Stroke (mm): 140mm, Capacity 90 Degrees: Square: 250 x 250, Capacity 45 Degrees: Round: 130mm, Capacity 45 Degrees: Square: 250 x 130, Main Drive Power (KW/V/Hz): 2hp / 415v

£5,300



## NEW Chester KP320

### 3010307260N - Hacksaw - Hydraulic

Manual/Automatic: Manual, Cutting Diameter (mm): 320mm, Dimensions Of Saw-Blade (mm): 500 x 38 x 2mm, Stroke (mm): 140mm, Capacity 90 Degrees: Square: 300 x 300mm, Capacity 45 Degrees: Round: 140mm, Capacity 45 Degrees: Square: 300 x 140mm, Main Drive Power (KW/V/Hz): 2hp / 415v

£5,900



## NEW Chester KP380

### 3010307261N - Hacksaw - Hydraulic

Manual/Automatic: Manual, Cutting Diameter (mm): 380mm, Dimensions Of Saw-Blade (mm): 550 x 45 x 2.25mm, Stroke (mm): 140mm, Capacity 90 Degrees: Square: 350 x 330mm, Capacity 45 Degrees: Round: 150mm, Capacity 45 Degrees: Square: 350 x 150mm, Main Drive Power (KW/V/Hz): 2hp / 415v

£6,700



## NEW Chester KP450

### 3010307262N - Hacksaw - Hydraulic

Manual/Automatic: Manual, Cutting Diameter (mm): 450, Dimensions Of Saw-Blade (mm): 650 x 50 x 2.5mm, Stroke (mm): 160mm, Capacity 90 Degrees: Square: 430 x 400mm, Capacity 45 Degrees: Round: 160mm, Capacity 45 Degrees: Square: 430 x 160mm, Main Drive Power (KW/V/Hz): 3hp / 415v

£12,100





# NEW Imaca DFH315

## 3015603930N - Circular Cut Off Saw - Pedestal

Saw Blade Diameter (mm): 315, Cutting Diameter (mm): 100, Capacity 45 Degrees: Round: 90, Capacity 45 Degrees: Flat: 70 x 85, Capacity 45 Degrees: Square: 80, Turning Speeds: 52 - 104 rpm, Main Drive Power (KW/V/Hz): 415v



# NEW Chester 350CS

## 3015607263N - Circular Cutting Off Machine - Pedestal

Saw Blade Diameter (mm): 350, Cutting Diameter (mm): 120, Capacity 45 Degrees: Round: 110, Capacity 45 Degrees: Flat: 135 x 110, Capacity 45 Degrees: Square: 120 x 120, Speeds: 19 / 38 rpm, Main Drive Power (KW/V/Hz): 1.5kw / 2hp / 415v

£2,116



# NEW Chester KV50

## 3020604436N - Vertical Bandaw

Horizontal / Vertical / Manual / Semi Au: Vertical, Saw Band Length (mm): 3840,  
Dimensions Of Saw-Band (mm): 16, Cutting Speed (M/S): 52-210fpm, Main Drive Power  
(KW/V/Hz): 1.5, Throat: 520, Max Work Height: 310mm, Table: 600 x 500

£6,804



# NEW Chester KV40

## 3020607255N - Vertical Bandaw

Horizontal / Vertical / Manual / Semi Au: Vertical, Saw Band Length (mm): 3285,  
Dimensions Of Saw-Band (mm): 3285 x 16, Cutting Speed (M/S): 20-80 mpm & 120-480  
mpm, Main Drive Power (KW/V/Hz): 1.5Kw, Throat: 410mm, Max Work Height: 300mm,  
Table: 600mm x 500mm

£6,264



## NEW Chester KV60

### 3020607256N - Vertical Bandaw

Horizontal / Vertical / Manual / Semi Au: Vertical, Saw Band Length (mm): 3950mm,  
Dimensions Of Saw-Band (mm): Max width 16mm, Cutting Speed (M/min): low 15 - 55 /  
high 96 - 390, Main Drive Power (KW/V/Hz): 1.5kw / 415v / 2hp, Throat: 600mm, Max Work  
Height: 300mm, Table: 600 x 500

£5,100



## NEW Chester KV100

### 3020607257N - Vertical Bandaw

Horizontal / Vertical / Manual / Semi Au: Vertical, Saw Band Length (mm): 4500mm,  
Dimensions Of Saw-Band (mm): Width max 16mm, Cutting Speed (M/min): low 15 -55 /  
high 96 - 390, Main Drive Power (KW/V/Hz): 1.5kw / 2hp / 415v, Throat: 1000mm, Max  
Work Height: 300mm, Table: 600 x 500mm

£5,800



## NEW TPH BP50/16

### 3505303970N - Box & Pan Folder

Box & Pan / Straight: Box & Pan, Plate Width (mm): 1270, Plate Thickness (mm): 1.0,  
Segmented Tools: Yes, Bending Angle Max.: 135

£1,295



## NEW Chester MF-12

### 3505304873N - Multiformer

Plate Thickness (mm): 1mm, Plate Width (mm): 305, Box & Pan / Straight: box & pan,  
Shearing mm: 0.6

£210



## NEW Chester 305

### 3505305166N - Box & Pan Folder

Segmented Tools: yes, Plate Thickness (mm): 1, Plate Width (mm): 305

£160



## NEW Chester FAB-FOLD-24

### 3505305250N - Box & Pan Folder

Bending Capacity ( Mild Steel): 1mm/20guage, Maximum Bending Length: 610mm

£250



## NEW Chester FAB-FOLD-36

### 3505305251N - Box & Pan Folder

Bending Capacity (Mild Steel): 1mm /20 Gauge, Maximum Bending Length: 915mm

£330



## NEW Chester FAB-FOLD-40

### 3505305252N - Box & Pan Folder

Bending Capacity ( Mild Steel): 1.5mm, Maximum Bending Length: 1050mm, Width of fingers: 250,150,100,75,50,45,40,35,30,25mm

£1,230



## NEW Chester FAB-FOLD-12

### 3505306052N - Box & Pan Folder

Bending Capacity ( Mild Steel): 1mm/20guage, Maximum Bending Length: 305mm

£160



## NEW Chester MF-24

### 3505307528N - Multiformer

Plate Thickness (mm): 1mm, Plate Width (mm): 610, Box & Pan / Straight: box & pan, Shearing mm: 0.6, Stand: Extra

£370



## NEW Chester 30

### 3505307529N - Multiformer

Plate Thickness (mm): 1mm, Plate Width (mm): 760, Box & Pan / Straight: box & pan,  
Shearing mm: 0.6

£470



## NEW Chester 40

### 3505307530N - Multiformer

Plate Thickness (mm): 1mm, Plate Width (mm): 1016, Box & Pan / Straight: box & pan,  
Shearing mm: 0.6

£850



## NEW Morgan -

### 3510004448N - Folders - Box & Pan, Straight, Manual & Hydraulic

Box & Pan / Straight: All, Plate Width (mm): Options, Plate Thickness (mm): Options



## NEW TPH LC Series

### 3515305370N - Back Gauge for retro-fitting on Pressbrakes

Control: CNC, Number Of Controlled Axis: 1 & 2 Axis, Number of Programs: 99, Number of Steps: 10 per program, Type: Manual & Automatic



## NEW Ercolina CE50MRE

### 3530005108N - Bending Rolls - Manual Section Rolls

Rolls: three, Main Drive Power: 3 phase, Angle Size (Leg Out): 60 x 60 x 6mm, Tube: 76mm 3.6mm

£6,800



## NEW TPH HV 40

### 3530006942N - Bending Rolls - Section Rolls

Rolls: Driven, Main Drive Power: 0.75kw / 415V, Angle Size: 50 x 50 x 4 mm, Flats: 60 x 20 mm, Tube: 30 x 2mm to 70 x 2mm (Special Roller), Square Tube: 50 x 50 x 2.5 mm, Round Bar: 30 mm, Square Bar: 30 x 30 mm

£2,650



## NEW Chester Fab-Roll-20

### 3535304892N - Bending Rolls - Hand

Initial Pinch / Double Pinch / Pyramid P: Pyramid, Plate Width (mm): 500, Diameter Of Top Rolls (mm): 37, Top Slip: Yes

£200



## NEW Chester Fab Roll 12

### 3535305165N - Bending Rolls - Hand

Plate Width (mm): 300, Diameter Of Top Rolls (mm): 25

£120



## NEW Chester SR50

### 3535305743N - Bending Rolls - Hand Slip

Plate Width (mm): 1300, Diameter Of Top Rolls (mm): 75, Stand: Optional extra

£695



## NEW Chester

### 3535305823N - Bending Rolls - Hand

Initial Pinch / Double Pinch / Pyramid P: Pyramid, Plate Width (mm): 305mm, Diameter Of Top Rolls (mm): 25, Top Slip: Yes

£109



## NEW Chester Fab Roll 24

### 3535306051N - Bending Rolls - Hand

Plate Width (mm): 610, Diameter Of Top Rolls (mm): 38, Thickness cap: 22swg

£240



## NEW TPH HBR50/3

### 3535603971N - Bending Rolls - Hand

Initial Pinch / Double Pinch / Pyramid P: Initial Pinch, Plate Width (mm): 1250, Plate Thickness (mm): 1.6, Diameter Of Top Rolls (mm): 75



## NEW TPH 1300/75

### 3535705125N - Bending Rolls - Hand

Diameter Of Top Rolls (mm): 75mm, Plate Width (mm): 1300mm, Initial Pinch / Double Pinch / Pyramid P: Initial Pinch, Plate Thickness (max): 1.5mm

£995



## NEW TPH 1300/75P

### 3535705126N - Bending Rolls - Power

Diameter Of Top Rolls (mm): 75mm, Plate Width (mm): 1300mm, Initial Pinch / Double Pinch / Pyramid P: initial Pinch

£1,998



## NEW TPH 2000/75

### 3535706216N - Bending Rolls - Hand

Diameter Of Top Rolls (mm): 75mm, Plate Width (mm): 2000mm, Initial Pinch / Double Pinch / Pyramid P: Initial Pinch, Capacity: 1.0mm

£1,500



## NEW Morgan -

### 3535904447N - Bending Rolls - Manual & Power

Initial Pinch / Double Pinch / Pyramid P: Alltypes, Plate Width (mm): Options, Plate Thickness (mm): Options



## NEW TPH 3030

### 3535905270N - Bending Rolls - Power

Plate Thickness (mm): 2.0, Plate Width (mm): 3030, Cone-Bending Device: yes, Diameter Of Top Rolls (mm): 160, Pre-Bending & Rolling: yes, Initial Pinch / Double Pinch / Pyramid P: Initial Pinch, Top Slip, Main Drive Power (KW/V/Hz): 3kw, Control: Portable Control Panel

£14,342



## NEW TPH 3030-3

### 3535905271N - Bending Rolls - Power

Plate Thickness (mm): 3.0, Plate Width (mm): 3030, Cone-Bending Device: yes, Diameter Of Top Rolls (mm): 180, Pre-Bending & Rolling: yes, Initial Pinch / Double Pinch / Pyramid P: Top slip, Main Drive Power (KW/V/Hz): 3kw, Control: Portable Control Panel, Balanced top roll: yes

£15,172



## NEW TPH 3030-4

### 3535905272N - Bending Rolls - Power

Plate Thickness (mm): 4.0, Plate Width (mm): 3030, Cone-Bending Device: yes, Diameter Of Top Rolls (mm): 200, Pre-Bending & Rolling: yes, Initial Pinch / Double Pinch / Pyramid P: Top slip, Main Drive Power (KW/V/Hz): 3kw, Control: Portable Control Panel, Balanced Top Roll: Yes

£15,892



## NEW TPH 3030-6

### 3535905273N - Bending Rolls - Power

Plate Thickness (mm): 6.0, Plate Width (mm): 3030, Cone-Bending Device: yes, Diameter Of Top Rolls (mm): 220, Pre-Bending & Rolling: yes, Initial Pinch / Double Pinch / Pyramid P: Initial Pinch, Top slip, Main Drive Power (KW/V/Hz): 5.5kw, Control: NC, Balanced Top Roll: Yes

£16,999



## NEW Ercolina TB60

### 3540005109N - Bending Machine - Rotary Tube

Bending Cap: 60mm x 3mm St St & Boiler Tube, Control: Micro Processor

£9,830



## NEW Chester FAB-AP-1/2

### 4005305259N - Arbor Press

Throat: 65mm, Tonnage: 1/2, 4 Position Plate diameter: 90mm, Ram Size Square: 19mm,  
Height: 280mm, Base Size: 105 x 240mm

£40



## NEW Chester FAB-AP-1

### 4005305260N - Arbor Press

Throat: 80mm, Tonnage: 1, 4 Position Plate Diameter: 110mm, Ram Size (Square): 25mm,  
Height: 355mm, Base size: 130 x 260mm

£60



## NEW Chester FAB-AP-2

### 4005305261N - Arbor Press

Throat: 120mm, Tonnage: 2, 4 Position Plate Diameter: 165mm, Ram Size (Square):  
32mm, Height: 445mm, Base size: 175 x 420mm

£120



## NEW Chester FAB-AP-3

### 4005305262N - Arbor Press

Throat: 140mm, Tonnage: 3, 4 Position Plate Diameter: 185mm, Ram Size (Square):  
38mm, Height: 615mm

£200



## NEW Sealy YK50

### 4030004445N - Hydraulic Workshop Press

Pressure (Ton): 50, Distance Between Table / Ram (mm): 615, Stroke (mm): 95, Table-Size (mm): 170mm wide



## NEW TPH 1320/1.5

### 4505305128N - Shear - Treadle

Cutting Cap - Thickness: 1.5mm, Cutting Cap - Length: 1300mm

£1,450



## NEW Chester HS6

### 4510304878N - Hand shear

Plate Thickness (mm): 6, Blade length: 150mm

£60



## NEW Chester HS5

### 4510305255N - Hand Shears

Length of Blades: 125mm, Capacity - Flat Steel: 6mm, Capacity - Round Steel: 11mm

£50



# NEW Chester HS8

## 4510305256N - Hand Shears

Length of Blades: 200mm, Capacity - Flat Steel: 6mm, Capacity - Round Steel: 13mm

£70



# NEW Chester HS10

## 4510305257N - Hand Shears

Length of blades: 250mm, Capacity - Flat Steel: 6mm, Capacity - Round Steel: 13mm

£80



# NEW TPH Inan HGM3006

## 4515905771N - Shear - Swing Beam Hydraulic

Blade Gap Adjustment: Yes, Plate Width - Max. (mm): 3000, Main Drive Power (KW/V/Hz): 11 kw, Back Gauge: Power (1 metre) with auto lift bar, Plate Thickness (mm): 6mm, Squaring Arm: Yes, Variable Cut: Yes, Sheet Supports: Yes, Guards: photo electric rear type



# NEW TPH Inan HGM30/13

## 4515905773N - Shear - Swing Beam Hydraulic

Blade Gap Adjustment: Yes, Plate Width - Max. (mm): 3000, Main Drive Power (KW/V/Hz): 22, Back Gauge: Power (1 metre) with auto lift bar, Plate Thickness (mm): 12mm, Squaring Arm: Yes, Variable Cut: Yes, Sheet Supports: Yes, Guards: photo electric rear type



# NEW Chester 4T

## 4525304857N - Bench Mounted Hand Notching Machine

Pressure (Ton): 4, Plate Thickness (mm): 1.6g, Blade Length (mm): 150mm

£365



# NEW TPH 150/1.5

## 4525305124N - Corner Notching Machine - Bench Mounted Hand

Blade Length (mm): 150mm, Plate Thickness (mm): 1.5mm, Stand: Extra

£395



## NEW Chester Tube notcher

4525305197N - Tube notcher

Max tube dia: 2", Hole saws supplied: No

£70



---

## NEW Chester FAB-NOT-4

4525305253N - Hand Notcher

Capacity: 4 Tons, Thickness: 1.6mm, Punches: 152 x 152mm, 90 Degree Angle: 152 x 152mm, Ram Stroke: 20mm

£370



## NEW Chester FAB-PUN-20

### 4525305254N - Hand Punch

Punches: 8mm Diameter 20mm / 10mm diameter 16mm, Throat Depth: 160mm, Punch Mould & Dye: 55 x 34 x 18mm

£370



## NEW Haco Mini 220/4

### 4525604309N - Corner Notcher - Hydraulic

Plate Thickness (mm): 4mm, Blade Length (mm): 200, Main Drive Power (KW/V/Hz): 415v/3ph/50hz

£4,980



## NEW Haco Maxi 250/6

### 4525604310N - Hydraulic Corner Notcher

Plate Thickness (mm): 6mm, Blade Length (mm): 250, Main Drive Power (KW/V/Hz): 415v/3ph/50hz

£7,150



# NEW Haco Vari 220/6

## 4530604311N - Corner Notcher - Variable Angle Hydraulic

Plate Thickness (mm): 6mm, Blade Length (mm): 200, Main Drive Power (KW/V/Hz): 415v/3ph/50hz

£11,200



# NEW Geka -

## 4545604446N - Steelworkers - Hydraulic

Hydraulic / Mechanical: Hydraulic, Pressure (Tons): 45 tons, Punch Throat Depth: 175 mm, Punch Max Diameter Through Max Thickness: 27 mm x 13 mm, Angles: Leg\*Leg\*Thickness (mm) At 90 Deg: 80x80x8 mm, Angles: Leg\*Leg\*Thickness (mm) At 45 Deg: 50 x50x6mm, Plate Shear: Length \* Thickness (mm): 300x10mm, Notching: Length\*Width\*Thickness (mm): 60x40x7 mm



# NEW Geka 55A

## 4545605110N - Steelworker - Hydraulic

Angles: Leg\*Leg\*Thickness (mm) At 90 Deg: 120 x 120 x 10mm, Plate Shear: Length \* Thickness (mm): 300 x 15mm, Punch Max Diameter Through Max Thickness: 40mm thr 10mm, Punch Throat Depth: 250mm, Pressure (Tons): 55, Hydraulic / Mechanical: Hyd, Notching: Length\*Width\*Thickness (mm): 100 90 x 10mm, Mains supply voltage: 3 phase

£8,800



## NEW TPH -

### 5005004462N - Swagers - Hand & Power

Sheet Thickness (mm): Options



## NEW TPH WN

### 5020004460N - Lockformers

Sheet Thickness (mm): 20g,16g, Main Drive Power (KW/V/Hz): 415v



## NEW TPH -

### 5030004461N - Flangers - Power



# NEW SIP

## 5505303843N - Spot Welder - Pneumatic Pedestal

Throat (min): 150mm, Throat (max): 440mm, Contact Pressure Capacity (N): 250, Welding Power: 15Kva, Distance between Arms: 290mm, Length of Arms: 500mm, Stroke (mm): 50mm, Electrode Stroke (mm): 50mm, Max Weld Cap MS Sheet: 3 + 3, Max Weld Cap MS Rod: 9 + 9, Power: 400v



## NEW SIP Ideal 350

### 5520004496N - Mig Welder

Current Intensity (A): 350



## NEW SIP Tig AC/DC160

5525604497N - 160 amp Tig Welder

Current Intensity (A): 160



## NEW SIP Plasma 30

5540004498N - Plasma Welder

Amperage - Max. (A): 30



## NEW Haco SMC3015

5540004619N - Plasma Cutter - CNC

Capacity: 3100mm x 1600mm

£33,500



## NEW Chester SBC 90

### 6000007338N - Sandblast Cabinets

Air Compressor Delivery: 100PSI @ 5CFM, Working Space: 560 x 460 x 280, Weight: 18KG

£111



## NEW Chester SBC 220

### 6000007339N - Sandblast Cabinets

Air Compressor Delivery: 40-80PSI @ 15-25CFM, Working Space: 600 x 840 x 630, Weight: 48KG

£308



## NEW Chester Range of

### 6015006847N - Slotting Machines

Strokes: from 350 to 1250mm



## NEW Chester Range of Borers available from 600mm

6055007253N - Borer - Vertical CNC



## NEW Chester HB Series

6055007254N - Borer - Horizontal CNC

Spindle Diameter (mm): 90-130, Spindle Taper: MT6, Table Surface Area (mm): 1000 x 920 to 1800 x 1600



## NEW Chester S Series

6080004429N - Shaping Machines



## NEW Chester S35

6080007335N - Shaper

Speeds : 32, 50, 80, 125, Stroke: 350mm, Motor: 1.5KW, Max Distance Lower Edge of Ram to Table: 330mm, Max Swivel of angle of Toolhead without : +- 90 Deg

£6,100



## NEW Chester S50

### 6080007336N - Shaper

Speeds : 15, 24, 37, 51, 64, 80, 102, 126, 158, Stroke: 500mm, Motor: 3KW, Max Distance Lower Edge of Ram to Table: 330mm, Max Swivel of angle of Toolhead without : +- 90 Deg

£8,000



## NEW Ferrari -

### 6520004459N - Top & Bottom Tooling for all Press Brakes



## NEW Silverflame -

### 6520004443N - Safety Guards for Milling Machines

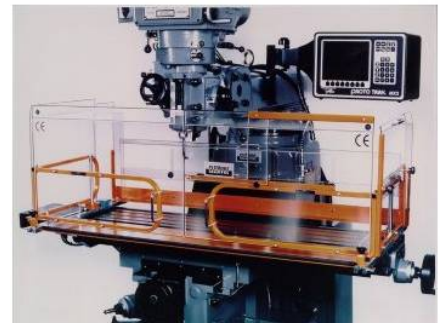

## NEW TPH -

### 6520004442N - Dividing Heads



## NEW TPH -

6520004441N - Machine Vices



## NEW TPH -

6520004440N - Chucks - 3 & 4 Jaw

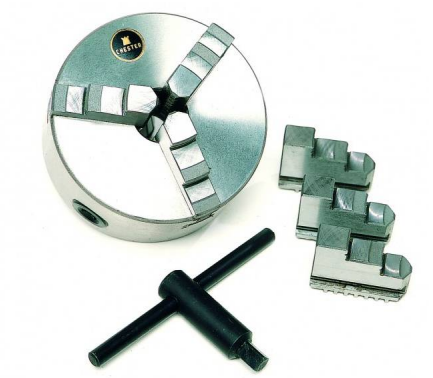

## NEW Chester -

6520004439N - Rotary Tables - Horizontal & Vertical





## NEW Chester WASH-PART-20

### 6520005266N - Parts Washer

Capacity: 54 Litres, Flow Rate: 4 L/Min, Stand: Included

£90



## NEW Chester WASH-PART-40

### 6520005267N - Parts Washer

Capacity: 136 Litres, Flow rate: 5-8 L/Min, Stand: Included

£200



## NEW Chester TBT2006

### 6520005268N - Tool Boxes

Width: 660mm, Depth: 322mm, Height: 366mm, Weight: 24 kgs

£111



# NEW Chester TB12002

## 6520005269N - Tool Boxes

Width: 668mm, Depth: 338mm, Height: 212mm, Weight: 13 kgs

£50



# NEW TPH VRNC 170

## 6520005354N - Rotary Tables (4th Axis) to suit KM80 VMC

£6,850

**VRNC-170B  
VRNC-210B  
VRNC-255B**

**CNC ROTARY TABLE**

- Rotatable diameter 170, 210 and 255 mm.
- Motor or powered or hand.
- Available with 4th axis or 5th axis.
- Enclosed and hand operation.
- 4th axis.

SPECIFICATIONS . . . . . Model	VRNC-170B	VRNC-210B	VRNC-255B
Worktable diameter	Ø170	Ø210	Ø255
Center height (Cheese)	135	160	160
Center hole diameter	Ø35 H7	Ø45 H7	Ø45 H7
Table size	214x214	224x224	224x224
Guide block size	18.5x	18.5x	18.5x
Number of worm gear teeth	72	72	72
Compliance indexing accuracy	Max. 30"	Max. 30"	Max. 30"
Repeatability	4"	4"	4"
Clamp system & Clamp method	Non-Pressure (press input) / (key-clamp) (press input) / (key-Pressure) (press input)		
Load capacity	Vertical 150kg Tallstack user 150kg	75kg 150kg	75kg 150kg
Allowable inertial force	4.5kg/cm/sec	4.5kg/cm/sec	4.5kg/cm/sec
Allowable turntable torque	18kg.cm	18kg.cm	18kg.cm
Max. Weight (presser included)	40.5kg	40kg	37.5kg
Motor mount (motor as required)	SANUKI   HELDAS   TMS-DAS   FANUC   MELDAS AC COU-1   HANANT-ES   AC COU-1   HANANT-ES   AC COU-1   HANANT-ES		
Speed reduction ratio	1/90	1/90	1/90
Maximum input current	0.50A <sup>1)</sup>	0.50A <sup>1)</sup>	0.50A <sup>1)</sup>
Table rotation speed (Motor 3000r.p.m.)	10.0r.p.m.	10.0r.p.m.	10.0r.p.m.

**CNC ROTARY TABLE**

# NEW Chester VG510

## 6520005732N - Accessory - Magnetic Chuck

Size: 125 x 250mm

£420



# NEW Chester VG612

## 6520005733N - Accessory - Magnetic Chuck

Size: 150 x 300mm

£472



## NEW Chester VG618

6520005734N - Accessory - Magnetic Chuck

Size: 150 x 450mm

£722



## NEW Chester VG816

6520005735N - Accessory - Magnetic Chuck

Size: 200 x 400mm

£774

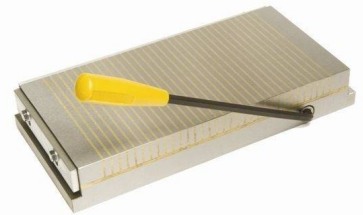

## NEW Chester VG1020

6520005736N - Accessory - Magnetic Chuck

Size: 250 x 500mm

£1,548



## NEW Chester -

6520005746N - Digital Readout Systems for Most Machines



## NEW Chester RAD

6520005799N - Radius Angle Dresser

Maximum Wheel Diameter: 11", Concave Cadius With Standard Diamonds: 0 - 21/4",  
Concave Cadius with RTA Tail Diamonds: 0 - 21/4", Tangent Travel in either direction:  
1.950", Centre Line: 3.4"

## NEW Chester X

6520007243N - Accessories - Power feed Unit

To fit X Axis: Yes

£414



## NEW Chester Y

6520007244N - Accessories - Power feed Unit

To fit Y Axis: Yes

£460



## NEW Chester Z

6520007245N - Accessories - Power feed Unit

To fit Z Axis: Yes

£460



## NEW Chester R8

### 6520007246N - Accessories - Air Powered Drawbar

To suit R8 Taper: yes, Max rpm: 3000

£580



## NEW Chester ISO40

### 6520007247N - Accessories - Air Powered Drawbar

To suit 40 international Taper: Yes, Max rpm: 3000

£580



## NEW Chester Digi Quill

### 6520007248N - Accessories - Digi Quill Readout

Fitting: Most Bridgeport type mills, LCD Display: 0.01mm / 0.0005" Resolution, Imperial / Metric: Both, SPC Data output: Yes, Effective movement: 145mm / 5.725"

£258



## NEW Silverflame -

### 6520007349N - Safety Guards for Lathes

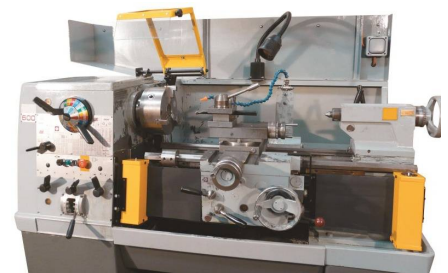

## NEW Silverflame -

6520007350N - Safety Guards for Drilling Machines



## NEW Silverflame -

6520007351N - Telescopic Leadscrew Guards for Lathes

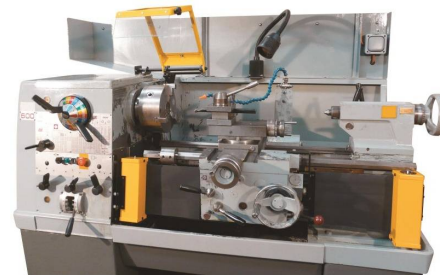

## NEW Geka

6520007367N - Accessories - Punch & Dies to suit Steelworkers

Round Punches: Yes, Square Punches: Yes, Slot or Square Punches: Yes, Slot Dies : Yes, Square Dies : Yes



## NEW Edwards

6520007388N - Accessories - Hold Down Pads for Edwards DD Shear

£13



## NEW Quick -

### 6530004444N - Cut Knurling Tools for Manual & CNC Lathes

For cutting Diamond & Cross 3mm - 250mm: Model A2 / KF, For cutting Straight Pattern 3mm - 250mm: Model A2 / FL, Cutting or pressure Knurls: Cutting, Knurling Tools for CNC Lathes: Yes, Knurling Tools for Manual Lathes: Yes, Knurling for Plastic: Yes, Knurling for Stainless Steel: Yes, Knurling for Aluminium: Yes, Video demonstration Available: Yes, Maximum precision and surface quality: Yes, Can be used for knurling thin materials : Yes, Cutting process save wear & tear on mc: Yes

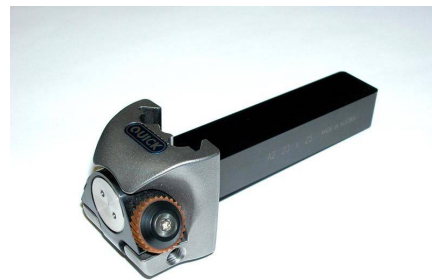

## NEW Chester VER - SVD - 200

### 6530006524N - Vice - Sine

Width of Jaw: 48mm, Angle : 0 -46 deg, Length: 155mm

£270

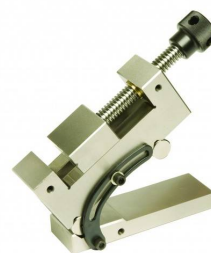

## NEW Chester HR250

### 6585005263N - Electric Hoist

Max Capacity Single line pull: 125kg, Max Capacity Double Line Pull: 250kg, Weight: 12 Kilos

£92



## NEW Chester HR400

### 6585005264N - Electric Hoist

Max Capacity Single Line Pull: 200kg, Max Capacity Double Line Pull: 400kg, Weight: 17 Kilos

£127



# NEW Chester HR800

## 6585007337N - Electric Hoist

Max Capacity Single Line Pull: 400kg, Max Capacity Double Line Pull: 800kg, Weight: 38 Kilos

£173

---

